

# Hydraulic Steering Systems



Rev. 11

Installation instructions and owner's manual

All Mavimare steering systems are certified CE by the Italian Shipping Register (Rina) in conformity with the 2013/53/EU rule.





## ■■■ CONTENTS

- Symbols used in this manual – General safety rules	page 4
- Two year limited warranty	page 5
- Operation of a hydraulic steering system	page 6
- Safety warnings	page 7
- Very important points to note - Minimum splashwell dimensions	page 8
- Installation instructions for GM3 MRA steering pump	page 9
- Installation instructions for GM0 / GM0-MRA01 steering pump	page 11
- Installation instructions for GM2-MRA01 / GM2-MRA03 / GM2-MRA04 / GM2-MRA05 steering pump	page 13
- Installation instructions for ORB fittings on GM3 / GM0 / GM2 series steering pump	page 15
- Installation instructions for MC 90B cylinder	page 16
- Installation instructions for MC 150BR cylinder	page 18
- Installation instructions for MC 150 cylinder	page 20
- Installation instructions for MC 150R / MC 300R cylinder	page 21
- Installation instructions for MC 300BHD Evolution cylinder	page 22
- Installation instructions for X.344 kit	page 24
- Ground strap installation instructions for MC 300BHD cylinder	page 25
- Double cylinder MC 300BHD installation scheme	page 26
- Installation instructions for MC 300HD - MC 350HD cylinder	page 27
- Ground strap installation instructions for MC 300HD – MC 350HD cylinder	page 29
- Twin engines application with tie bar code 358.00 - 358.06	page 30
- Twin engines installation with tie bar code 358.02	page 31
- Triple engine application with two cylinder and tie bar code 358.08 - 358.08R / code 359.09 - 359.08R	page 32
- Twin engines application with tie bar code 358.07 - 358.08 / 358.09 - 358.10	page 33
- Installation instruction for ORB fitting on MC 90B / MC 150BR cylinder	page 34
- Installation instruction for ORB fitting on MC 300HD / MC 350HD cylinder	page 34
- Installation instructions for GE30 / GE50 / GE75 / GE100 cylinder	page 36
- Installation instructions for MC 150E / MC 150BE / MC 300BE cylinder	page 38
- Installation instructions for CE50S cylinder	page 40
- SAE100R7 hydraulic hose installation	page 41
- Hoses / fittings installation - pump connection	page 43
- Connection schemes for double cylinder application -- code X.351 / code X.352	page 44
- Hydraulic fluid	page 45
- Filling and purging – outboard cylinder	page 45
- Filling and purging – inboard / sterndrive cylinder	page 48
- Valves installation	page 50
- Dual station installation	page 50
- Catamaran outboard system	page 51
- Troubleshooting guide	page 53
- Faults and solutions	page 54
- Maintenance	page 55
- Technical informations	page 55







### ■■■ Symbols used in this manual

The present INSTALLATION AND MAINTENANCE MANUAL must accompany the product from the date of purchase until discharge and must be considered an integral part of the product.

It should be easily available to staff in charge of use and maintenance. The user must be adequately informed of its contents before carrying out any operation inherent therein.

For the safety of the user and to guarantee the correct use of the product, the symbols shown below are used in the manual.

 <b>DANGER</b>	Indicates that a hazard exists that could cause serious personal injury or death. Failure to observe a hazard may result in immediate damage to the vessel, serious personal injury leading to death
 <b>WARNING</b>	Indicates a reminder to apply safe practices or calls attention to unsafe practices. Failure to comply may result in injury or damage to the boat or components.
 <b>NOTE</b>	Information deemed important for correct installation and maintenance.
	Operations that involve user risks are indicated in this manual with the symbol shown aside. Staff must be specialized and adequately trained to have the knowledge necessary for the installation and use of the product.

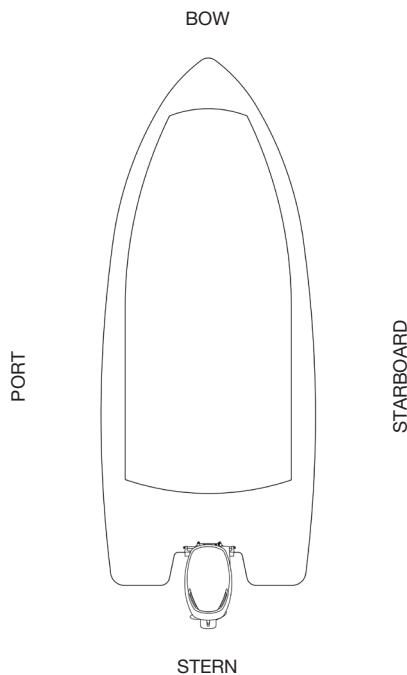

The picture aside facilitates understanding of the nautical terminology used in the manual.

### ■■■ General safety rules

Thank you for choosing a MAVIMARE product.

Before proceeding with the installation, handling or unloading of the above from the means of transport, read these instructions thoroughly.

The present installation and maintenance manual is an integral part of the product and must be easily available for use by staff assigned in use and maintenance of the same. The user is required to know the contents of the manual. MAVIMARE disclaims all responsibility for any inaccuracies due to printing errors contained in this manual. Without prejudice to the essential characteristics of the product described, MAVIMARE reserves the right to make any changes to descriptions, information, and illustrations that should be determined for the improvement of the same, or for manufacturing or commercial requirements at any time and without being required to update this publication.

MAVIMARE cannot accept responsibility for installations where instructions have not been followed, where substitute parts have been used or where changes have been made to its products.

#### **DANGER**

The hydraulic steering system shall be installed by authorised and skilled technicians. Most importantly, the interventions on the hydraulic piping system shall be carried out by expert technicians only.

Any operating anomalies of the device must be reported immediately to authorized expert technicians. Alternatively, our technical assistance service must be contacted at the email address [service@mavimare.com](mailto:service@mavimare.com).

Use only original spare parts when replacing components. The manufacturer declines any responsibility in case of non-compliance.

## ■ ■ ■ Two year limited warranty

MaviMare & Mancini SRL warrants that all products manufactured and sold by MaviMare & Mancini SRL are free from defects in material and workmanship for a period of two years from the date of original retail purchase, with the exception of cases in which these are installed and used commercially or in any rental or other income producing activity, in which case the warranty is limited to one year from the date of purchase.

### Exclusions

This limited warranty does not cover and does not extend to any product which:

- A. has not been properly installed: installation should only be carried out by a trained and qualified technician;
- B. has been installed in a way other than as recommended in MaviMare & Mancini SRL installation or operation instructions or specifications;
- C. has failed or has been damaged due to normal wear and tear, climatic conditions, misuse, neglect, lack of proper maintenance, accident, fire or other casualty damage, racing, overloading, negligence, modification, beaching or grounding of vessel, collision, impact, towing, acts of war or hostilities;
- D. has been repaired or modified by entities other than MaviMare & Mancini SRL;
- E. has been used on an engine/boat combination where the engine horsepower exceeds the rating established by the boat manufacturer;
- F. has been used with other product(s) which, in MaviMare & Mancini SRL's opinion, are incompatible with the MaviMare & Mancini SRL product;
- G. has not been manufactured by MaviMare & Mancini SRL, whether or not warranted by the other manufacturer;

### Limitations

THE REPAIR OR REPLACEMENT OF DEFECTIVE PARTS SHALL BE PURCHASER'S SOLE AND EXCLUSIVE REMEDY AND MAVIMARE & MANCINI SRL'S SOLE AND EXCLUSIVE LIABILITY UNDER THIS WARRANTY. COST OF REMOVAL OR REINSTALLATION OF ANY COMPONENT (INCLUDING COMPONENTS MANUFACTURED BY MAVIMARE & MANCINI SRL), OR DISASSEMBLY AND REASSEMBLY OF THE UNIT CONTAINING THE COMPONENT ARE NOT INCLUDED.

MaviMare & Mancini SRL's obligation under this warranty is limited to the repair or replacement (at MaviMare & Mancini SRL's sole discretion) of any covered item found to be defective, when delivered by Purchaser pursuant to written authorization and instructions from MaviMare & Mancini SRL, shipping prepaid to MaviMare & Mancini SRL's plant, or other designated repair facility. Repaired or replaced items are warranted as provided herein for the unexpired portion of the applicable warranty period.

THIS WARRANTY, AND THE RIGHTS AND REMEDIES UNDER IT, IS EXCLUSIVE AND IS GIVEN IN PLACE OF ALL OTHER WARRANTIES, WHETHER EXPRESS OR IMPLIED, INCLUDING ANY IMPLIED WARRANTY OF MERCHANTABILITY OR FITNESS FOR PARTICULAR PURPOSE, WHETHER ARISING BY LAW, CUSTOM, CONDUCT OR USAGE OF TRADE. THIS WARRANTY WILL BE THE CUSTOMER'S EXCLUSIVE REMEDY. IN NO EVENT WILL MAVIMARE & MANCINI SRL BE LIABLE FOR ANY INCIDENTAL OR CONSEQUENTIAL DAMAGES FOR BREACH OF ANY EXPRESS OR IMPLIED WARRANTY RELATING TO THE PRODUCTS.

### Transferability of warranty

This limited warranty may not be transferred to subsequent purchasers.

### Miscellaneous

MaviMare & Mancini SRL reserves the right to make changes in the design and construction of its products at any time, without notice and without any obligation to incorporate such changes into products of prior manufacture. This limited warranty applies to new components sold by MaviMare & Mancini SRL. This limited warranty contains the entire agreement between MaviMare & Mancini SRL and Purchaser and supersedes all prior agreements, discussions, negotiations, commitments and declarations, whether oral or written, between them regarding MaviMare & Mancini SRL's warranty. If any provision of this limited warranty, or the application of it, is determined to be invalid or unenforceable for any reason, the remainder of this limited warranty and the application of it shall not be affected.

### Returns policy

Any product that is presumed defective should be reported to MaviMare & Mancini SRL within 48 hours of receipt. Upon notification MaviMare & Mancini SRL will attempt to troubleshoot the problem with our customer over the phone. If the problem cannot be resolved MaviMare & Mancini SRL will issue a Return Goods Authorization number requiring that the product in question be returned to MaviMare & Mancini SRL with all of its parts in its original packaging. The product should be returned carriage paid/free port to:

MaviMare & Mancini SRL  
Via Manzoni, 26  
20089 Rozzano (MI)

Upon receipt MaviMare & Mancini SRL will examine the product to determine the cause of the defect. If the product is determined to have a defect in workmanship or material, it will be repaired or replaced at MaviMare & Mancini SRL's discretion

### ■ ■ ■ Operation of a hydraulic steering system

MAVIMARE hydraulic steering systems are designed to ensure the best possible performance in all conditions and in all situations of navigation. Specifically developed for marine operation in the temperature range of  $-15^{\circ}\text{C}$  ( $5^{\circ}\text{F}$ ) to  $+70^{\circ}\text{C}$  ( $+158^{\circ}\text{F}$ ), the systems are made with anti-corrosion materials to ensure a long life and maximum reliability.

The hydraulic steering system consists of a system of pumps, cylinders and hoses, and uses hydraulic fluid (hydraulic oil) to transmit force from the rudder to the pilot.

The hydraulic system may be schematically represented by a hydraulic drive pump, located on the control console, a hydraulic cylinder installed at the stern and connected to the rudder of the boat's engine, finally by hydraulic hoses that connect through specific pump and cylinder connections close the the circuit within which the hydraulic oil flows (see picture).

The rotation of the steering wheel exerts a force which is transmitted to the pump, which, through the push of the pistons, puts pressure on the oil in the circuit that is being charged, depending on the direction of rotation, in one of the two chambers of the cylinder thus transforming the motion from rotary to linear.

The resulting movement of the cylinder means that the oil in the second chamber of the cylinder flows through the pipes to the pump. This process drives the cylinder which, in turn, is connected to the engine tiller and moves it.

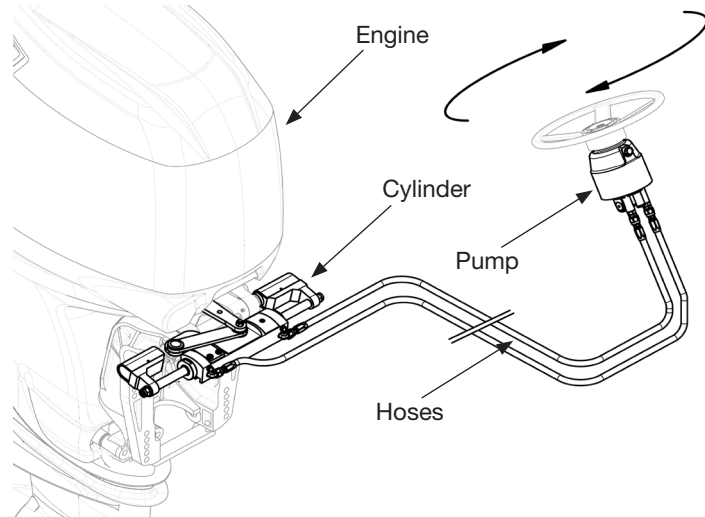

All MAVIMARE pumps are equipped with a non-return valve that prevents oil from flowing to the pump if it is not operated. This prevents any action on the tiller from generating return forces on the steering wheel. This valve allows the installation of systems with two or more driving stations. In addition, all MAVIMARE pumps are equipped with a maximum pressure valve that ensures that the maximum operating pressure in the system is set to  $7.0\text{ MPa}$  ( $70\text{ bar}/1000\text{ PSI}$ ). Above this pressure, the valve is operated so that the circuit releases the accumulated pressure.

The cylinders as described above are double acting and can be balanced or unbalanced. In the first case, the volume of the two chambers is equal and the number of turns of the steering wheel necessary to move the rudder from band to band, on port or starboard, will be the same.

In the second case, the volume of the two chambers is different. Therefore, the number of turns of the steering wheel required to move the rudder from band to band, on port or starboard, will be different, as well as the force to be applied on the steering wheel to move the rudder in both directions.

Depending on the hydraulic pump model installed, the ability to de-multiply steering effort will be affected: the bigger the pump the less turns of steering wheel will be needed for its run but the greater the effort to exert on the steering wheel itself and vice versa.

For this reason, the choice of the correct pump/cylinder combination is essential to obtain a balanced and efficient driving system.

MAVIMARE produces different models of pumps, which differ in the flow rate ( $\text{cm}^3/\text{cu.in.}$ : of oil moved at each turn of the steering wheel). The choice of pump type shall be considered in relation to the fact that the speed at which the engine's rudder is driven from belt to belt is the result of the ratio between the volume of the cylinder and the pump flow rate. It is advisable to choose a cylinder/pump combination that allows you to achieve a number of turns of the steering wheel between 4 and 8 maximum. A lower value would require excessive force to move the steering wheel, significantly affecting the handling of the wheelhouse. On the contrary, a value greater than 8 would make the rudder response too slow after the cylinder is actuated.

Here is an example for calculating the number of turns of the steering wheel from band to band.

Considering a pump with a flow rate of  $27\text{ cm}^3$  ( $1.65\text{ cu.in.}$ ) and a cylinder with a volume of  $138\text{ cm}^3$  ( $8.42\text{ cu.in.}$ ), the number of revolutions of the steering wheel from band to band is obtained from the following ratio:  $138\text{ cm}^3/27\text{ cm}^3 = 5.1$  ( $8.42\text{ cu.in.}/1.65\text{ cu.in.} = 5.1$ )

### ■■■ Safety warnings

YOU MUST STRICTLY TAKE the precautions and comply with the advisable safety criteria here below. MAVIMARE declines any responsibility in the case you do not observe them and also for any case of negligence that might be committed during the utilization of the system.

 DANGER

Keep hands clear of moving parts.

 DANGER

Do not deactivate and do not make safety devices inoperative in any way.

 DANGER

Do not change or add devices to the system, without written authorization or previous technical intervention of MAVIMARE which shall approve it. In this case the steering system may not operate safely and may endanger the vessel and its occupants. The responsibility for changes or modifications (safety-related) to the driving system by the user is solely with the user.

 DANGER

Do not use the system for any other purpose than for what specified in the installation and maintenance manual. All MAVIMARE hydraulic steering systems cannot be applied on racing boats.

 WARNING

Do not disassemble the hydraulic connections without having completed the oil discharge in the system before. The piping can contain high-pressure oil.

 WARNING

MAVIMARE hydraulic steering systems must be applied on boats equipped with engines that do not exceed the maximum installable powers set by MAVIMARE

 WARNING

Do not step onto the cylinder.

 WARNING

After installation and bleeding the system, check before you start the navigation. Turn the steering wheel until the cylinder or cylinders are at the stroke end. Repeat the maneuver rotating the steering wheel in the opposite direction. Repeat the operation with all the systems in place until you are sure of correct installation and system performance.

 WARNING

Take the utmost care when applying liquid gluing material (e.g. Loctite). In case of introduction in the hydraulic system, this would cause damages and disruptions.

 WARNING

To seal the fittings, do not use (under any circumstances) Teflon tape or any type of tape that could be sucked in by the system and cause irreparable damage to the same.

 WARNING

During installation of the system take special care to maintain maximum cleaning, to prevent foreign matter from entering the system. Even the smallest object could result in permanent damage not immediately detectable.

 WARNING

Avoid bending the tubes too tight.

 WARNING

Avoid contact with piping edges or sharp corners.

 WARNING

Keep pipes away from sources of heat.

**Do not allow non-specialised personnel to perform installation.**

■■■ Very important points to note

**WARNING**

Do not use brake fluid – it will damage seals and other components.  
Use only **MAVIMARE** hydraulic oil.  
Use of alternative hydraulic fluids may result in premature seal wear and possibly cause damage to your system.  
**DO NOT USE Automatic Transmission Fluid.**

**WARNING**

**DO NOT RE-USE OIL FROM BLEEDING THE SYSTEM** without first filtering it to remove foreign material (which will come out of the system), and ALWAYS allow the air to settle out of it first. YOU WILL REQUIRE FAR MORE OIL TO BLEED THE SYSTEM THAN YOU NEED TO FILL THE SYSTEM.

**NOTE**

Allow about 1 or 2 litres, for a small single station unit and about 5 litres for a small dual station unit.

**WARNING**

WHEN INSTALLING **MAVIMARE** STEERING SYSTEMS YOU MUST USE ONLY **MAVIMARE** HOSES.  
The performance of the steering can be seriously affected by the wrong tubing being installed. Before making any change to the tubing specs, contact your authorised **MAVIMARE** dealer or the factory directly.

**NOTE**

**IMPORTANT:** All outboard motors are equipped with small “TRIM” tabs immediately behind the propeller. In some motors, these also act as anodes.

**DO NOT UNDERESTIMATE THE IMPORTANCE OF THESE SMALL ITEMS.**

These must be adjusted once the motors are installed on the boat. The adjustment should be done for the normal cruising speed of the vessel. For high horsepower/performance motors, these are of critical importance as incorrect position can INCREASE steering torques as much as 500%. They are NOT factory set and MUST be done after proper installation. Experimentation is the only means of arriving at the best results.

**WARNING**

BE CLEAN when installing the unit.

- Strain all oil - even if new (unless out of new PLASTIC containers). It only takes a few moments to do this.
- Keep the filler cap and the plugs in the pump at all times until the tubing is ready for attachment.
- Never leave the pump with the filler cap open or fittings uncovered to avoid dirt, sawdust etc. from entering the pump unit.
- Ensure that pipe joints and fittings are tight.
- Avoid the use of Teflon Tape as it can be introduced into the system by inexperienced installers. THIS MAY CAUSE VALVE FAILURE.

**WARNING**

After installation, check the security of all bolts, nuts, and split pins on the steering mechanism. Vibration can often result in nuts becoming loose. This check should be carried out every 6 months.  
Use compressed air and blow out all tubing to remove dust and debris from storage. DO NOT CUT WITH A HACKSAW – USE ONLY PIPE CUTTER. Where the tubing is to be bent, you should use a proper tube-bender to avoid kinking the tubing, which could result in firm steering.

■■■ Minimum splashwell dimensions

Before attempting installation, ensure that the splashwell of your boat has the following minimum dimensions:

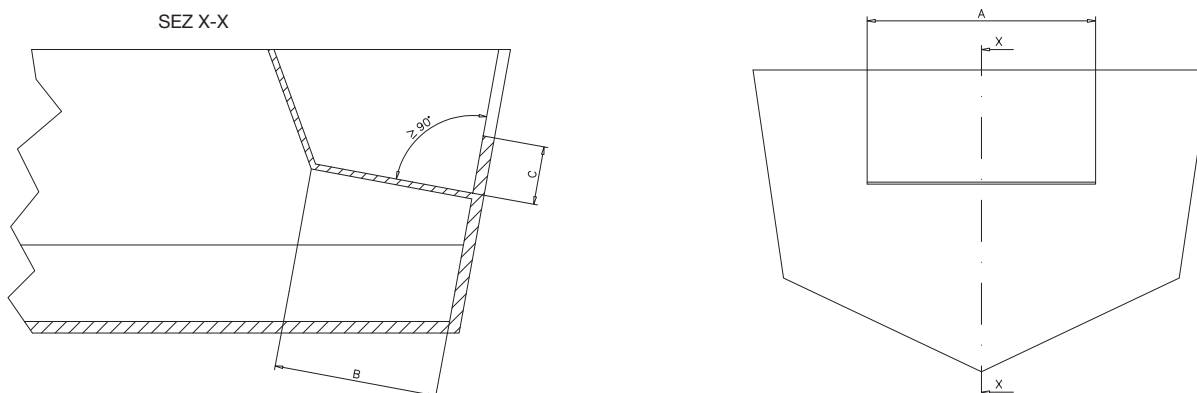

Minimum splashwell dimensions			
Number of engines	A	B	C
1	560 mm (21.25")	152 mm (5.98")	152 mm (5.98")
2	1110 mm (43.70")	152 mm (5.98")	152 mm (5.98")



### ■■■ Installation instructions for GM3 MRA steering pump

Select a suitable position for the steering pump and the steering wheel. Make sure that there is enough manoeuvring space for the steering wheel, for the steering pump and its connections and pipes.

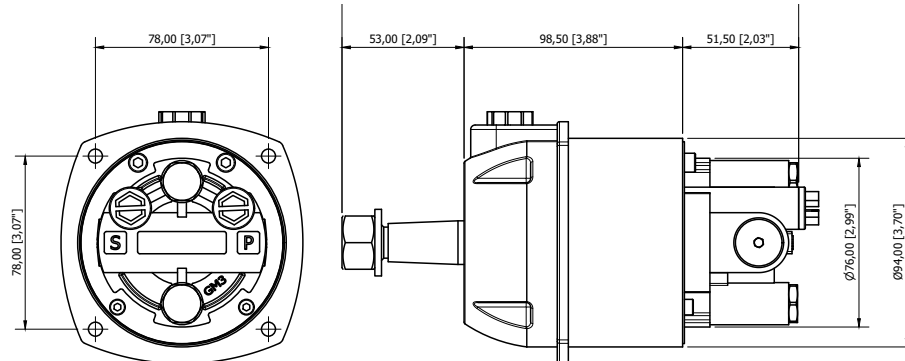

#### NOTE

Before making any bleeding operation, the pump can be mounted at a maximum inclination of  $20^\circ$  (ref. angle X - picture 2). If the pump is tilted at more than  $20^\circ$ , make bleeding operation with the pump in a horizontal position and then place it on the dashboard. The filler plug (ref. 1 - picture 2) must always be in the uppermost position.

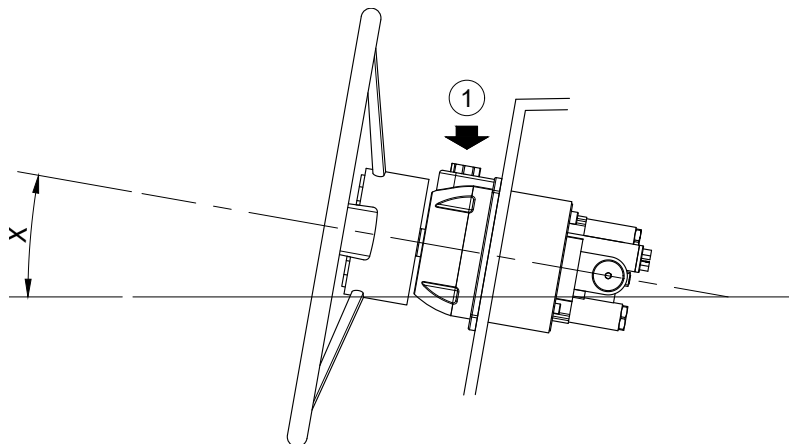

#### WARNING

Keep the filler cap and the plugs in the pump at all times until the tubing is ready for attachment. Never leave the pump with the filler cap open or fittings uncovered to prevent dirt, sawdust etc. from entering the pump unit.

#### NOTE

Do not overtighten the fitting plug.

### Installation steps



**STEP 1** - Unscrew the protective caps (1) and screw the ORB fittings (2) following the procedure described on page 15.

#### WARNING

Do not use teflon tape or any other type of adhesive tape at this stage.  
Do not apply any type of sealant fittings such as Loctite 542 or similar.

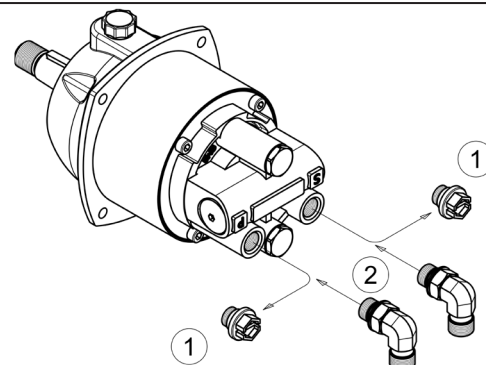

**STEP 2** - Cut a hole for the steering pump housing of diam. 95 mm and four holes diam. 6.5 mm for the fixing bolts.

**NOTE**

In this step use the dashboard mounting template supplied with the pump.

After inserting the 4 M6x60 screws (1), the stainless-steel washers (2) and the 4 nylon washers (3), using a 10 mm open end wrench and a 4 mm allen wrench, tighten the 4 M6 nuts (4) with a torque of 10 Nm (7.4 lb ft).

**WARNING**

Use only self-locking fasteners. If they are removed, it will be necessary to replace them.

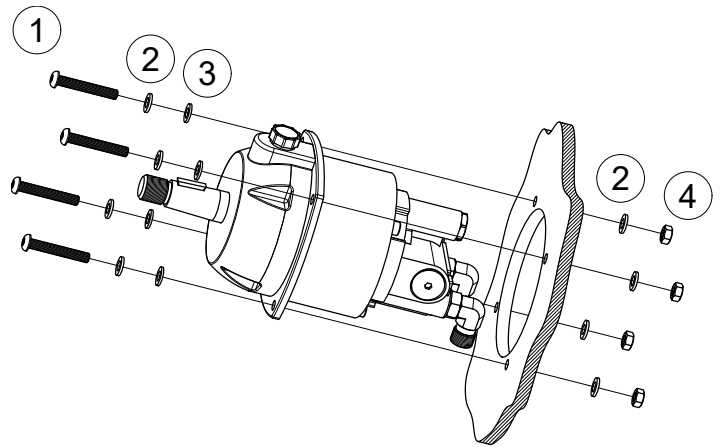

**STEP 3** - Insert the steering wheel into the pump shaft by aligning it with the appropriate key. Insert the washer and use a 24 mm open end wrench. Tighten the self-locking nut with a torque of 40 Nm (29.5 lb ft).

**WARNING**

In this step, before inserting the wheel and screwing the nut, grease the thread and conical part of the pump shaft with high quality marine grease.

**WARNING**

If the self-locking nut is removed when removing the steering wheel, the lock nut must be replaced.

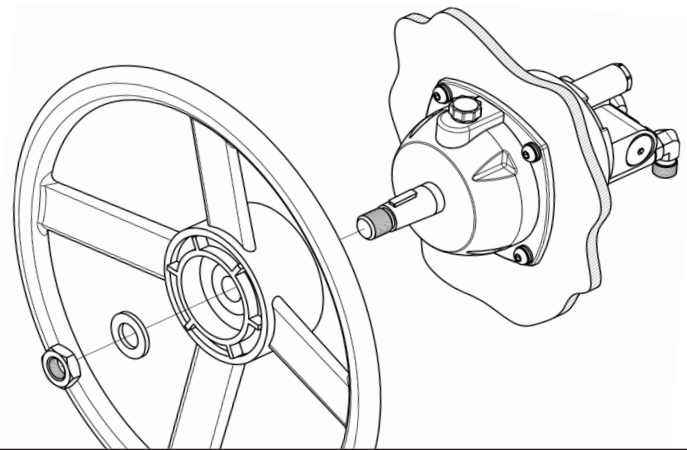

### ■■■ Installation instructions for GM0 / GM0-MRA01 steering pump

Select a suitable position for the steering pump and the steering wheel. Make sure that there is enough manoeuvring space for the steering wheel, for the steering pump and its connections and pipes.

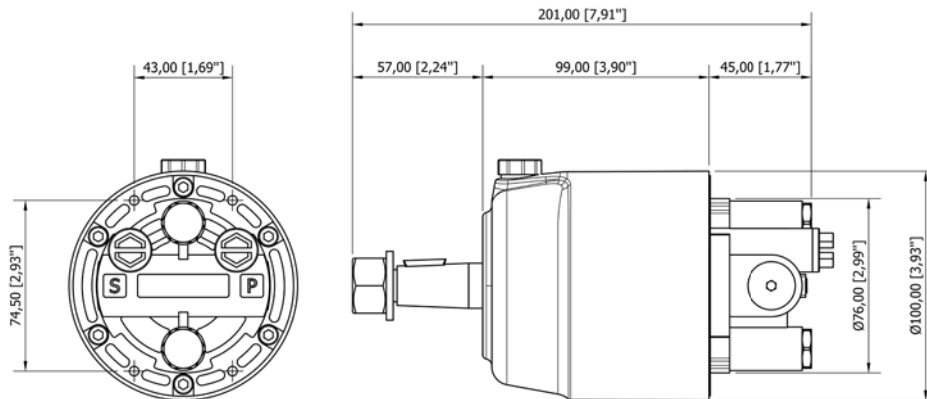

#### NOTE

Before making any bleeding operation, the pump can be mounted at a maximum inclination of 20° (ref. angle X - picture 2). If the pump is tilted at more than 20°, make bleeding operation with the pump in a horizontal position and then place it on the dashboard. The filler plug (ref. 1 - picture 2) must always be in the uppermost position.

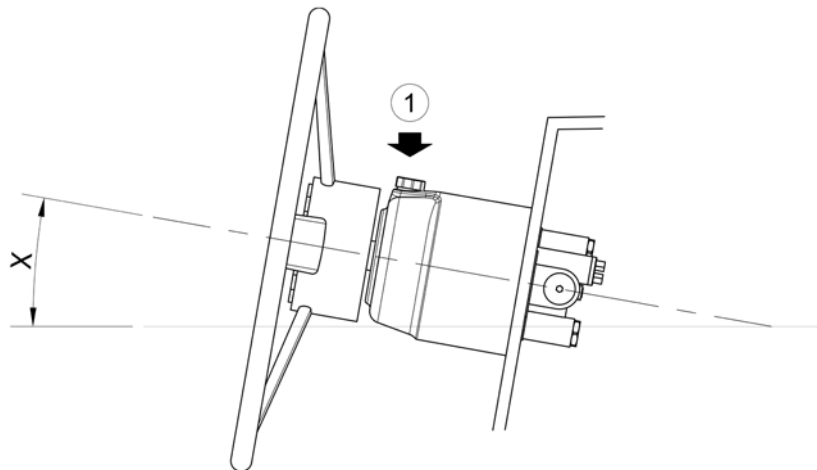

#### WARNING

Keep the filler cap and the plugs in the pump at all times until the tubing is ready for attachment. Never leave the pump with the filler cap open or fittings uncovered to prevent dirt, sawdust etc. from entering the pump unit.

#### NOTE

Do not overtighten the fitting plug.

### Installation steps

**STEP 1** - Screw, using a 2.5 mm allen wrench, the 4 M5 captive screws in the threaded holes on the pump valve until they reach the strike.

#### WARNING

In this step, in order to lock the captive screws, apply sealant Loctite 542.

#### WARNING

Avoid applying additional force when screwing the captive screws as this could result in valve damage and make the pump unusable.

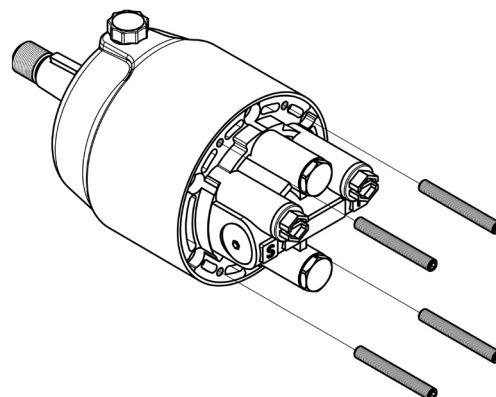

**STEP 2** - Unscrew the protective caps (1) and screw the ORB fittings (2) following the procedure described on page 15.

**WARNING**

Do not use teflon tape or any other type of adhesive tape.  
Do not apply any type of sealant fittings such as Loctite 542 or similar.

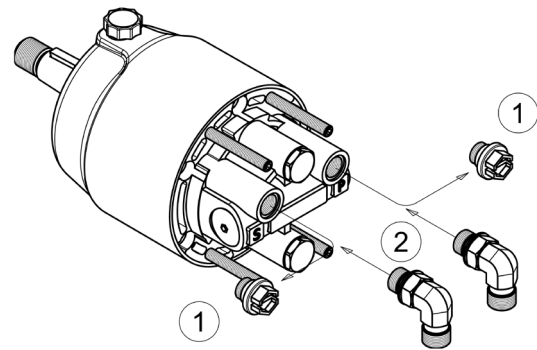

**N.B In case of pump standard installation proceed with step 3-A**

**STEP 3-A** - Cut a hole for the steering pump housing of diam. 78 mm and four holes diam. 6 mm for the fixing bolts.

**NOTE**

In this step use the dashboard mounting template supplied with the pump.

After inserting the washers, using a 8 mm open end wrench, tighten the 4 M5 nuts with a torque of 10 Nm (7.4 lb ft).

**WARNING**

Use only self-locking fasteners. If they are removed, it will be necessary to replace them.

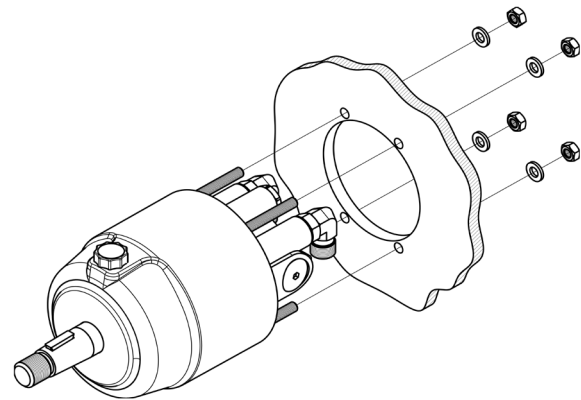

**N.B In case of pump standard installation with back mount kit proceed with step 3-B.**

**STEP 3-B** - Cut a hole for the steering pump housing of diam. 103 mm and four holes diam. 6.5 mm for the fixing bolts.

**NOTE**

In this step use the dashboard mounting template supplied with the pump.

1 - After inserting the washers, using a 8 mm open end wrench, attach the metal flange to the valve by tightening the 4 M5 nuts on the studs with a torque of 10 Nm (7.4 lb ft).

2 - After placing the plastic flange on the console, attach it to the metal flange using 4 screws M6 x 60 mm, the 4 aluminium spacers, the 4 washers and the 4 M6 nuts. Using a 4 mm allen wrench and a 10 mm open end wrench, tighten the nuts with a torque of 10 Nm (7.4 lb ft).

3 - Apply plastic closure caps.

**WARNING**

Use only self-locking fasteners. If they are removed, it will be necessary to replace them.

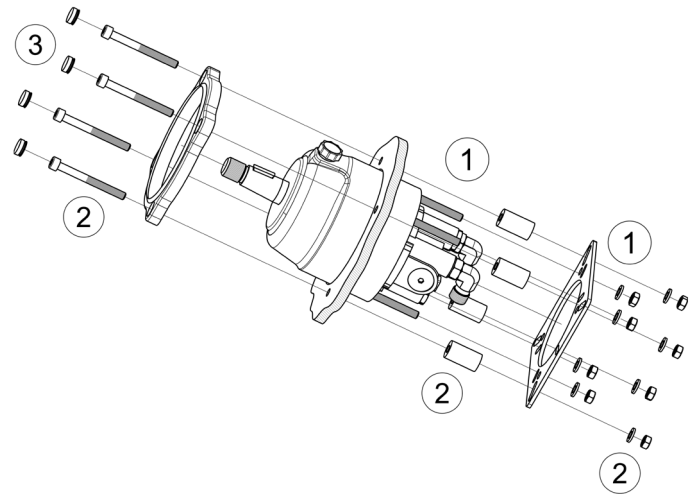

**STEP 4** - Insert the steering wheel into the pump shaft by aligning it with the appropriate key. Insert the washer and use a 24 mm open end wrench. Tighten the self-locking nut with a torque of 40 Nm (29.5 lb ft).

**WARNING**

In this step, before inserting the wheel and screwing the nut, grease the thread and conical part of the pump shaft with high quality marine grease.

**WARNING**

If the self-locking nut is removed when removing the steering wheel, the lock nut must be replaced.

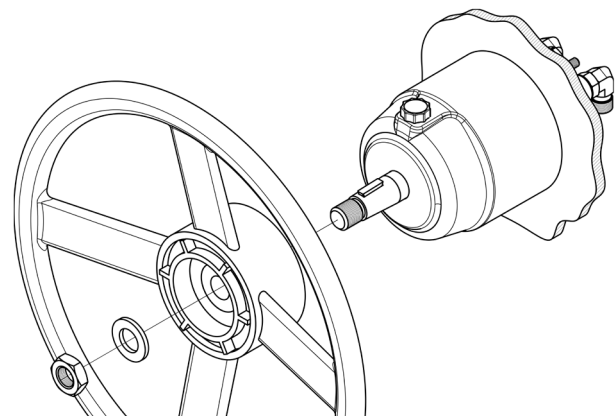

### ■■■ Installation instructions for GM2-MRA01 / GM2-MRA03 / GM2-MRA04 / GM2-MRA05 steering pump

Select a suitable position for the steering pump and the steering wheel. Make sure that there is enough manoeuvring space for the steering wheel, for the steering pump and its connections and pipes.

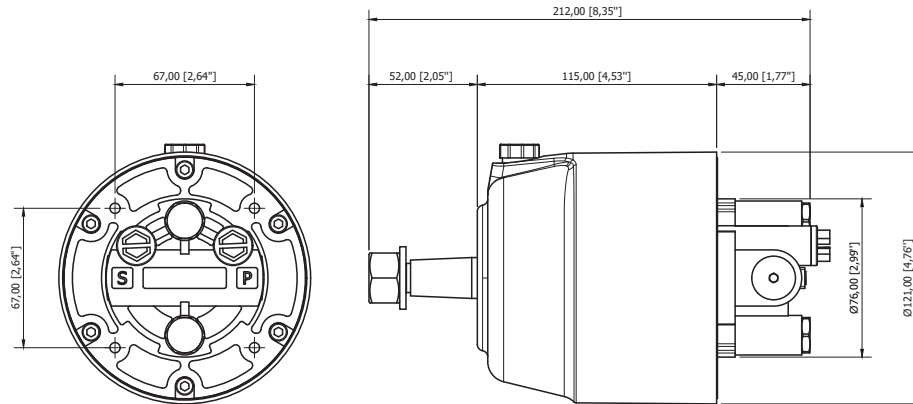

#### NOTE

Before making any bleeding operation, the pump can be mounted at a maximum inclination of 20° (ref. angle X - picture 2). If the pump is tilted at more than 20°, make bleeding operation with the pump in a horizontal position and then place it on the dashboard. The filler plug (ref. 1 - picture 2) must always be in the uppermost position.

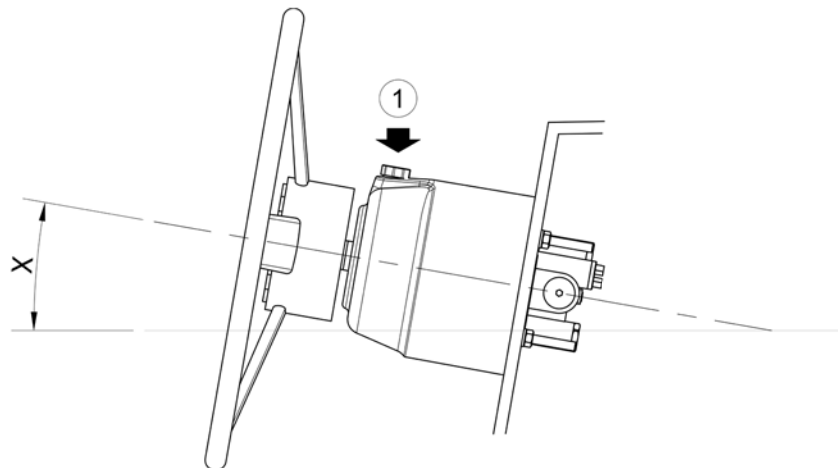

#### WARNING

Keep the filler cap and the plugs in the pump at all times until the tubing is ready for attachment. Never leave the pump with the filler cap open or fittings uncovered to prevent dirt, sawdust etc. from entering the pump unit.

#### NOTE

Do not overtighten the fitting plug.

### Installation steps



**STEP 1** - Screw, using a 3 mm allen wrench, the 4 M6 captive screws in the threaded holes on the pump valve until they reach the strike.

#### WARNING

In this step, in order to lock the captive screws, apply sealant Loctite 542.

#### WARNING

Avoid applying additional force when screwing the captive screws as this could result in valve damage and make the pump unusable.

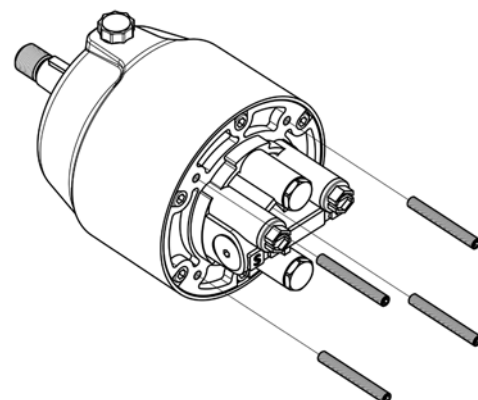

**STEP 2** - Unscrew the protective caps (1) and screw the ORB fittings (2) following the procedure described on page 15.

**WARNING**

Do not use teflon tape or any other type of adhesive tape.  
Do not apply any type of sealant fittings such as Loctite 542 or similar.

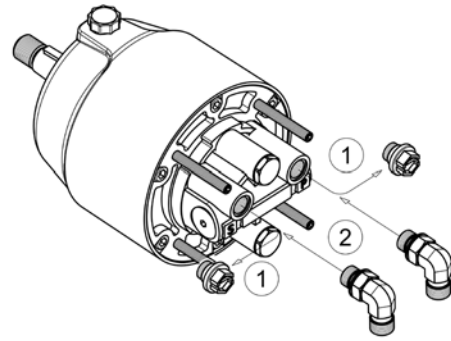

**N.B In case of pump standard installation proceed with step 3-A**

**STEP 3-A** - Cut a hole for the steering pump housing of diam. 78 mm and four holes diam. 6.5 mm for the fixing bolts.

**NOTE**

In this step use the dashboard mounting template supplied with the pump.

After inserting the washers, using a 10 mm open end wrench, tighten the 4 M6 nuts with a torque of 10 Nm (7.4 lb ft).

**WARNING**

Use only self-locking fasteners. If they are removed, it will be necessary to replace them.

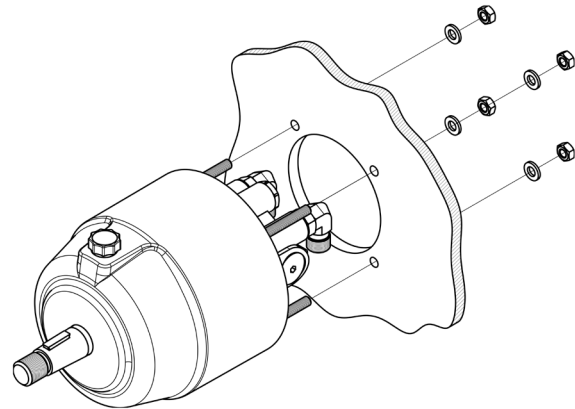

**N.B In case of pump installation with back mount kit proceed with step 3-B.**

**STEP 3-B** - Cut a hole for the steering pump housing of diam. 121 mm and four holes diam. 6.5 mm for the fixing bolts

**NOTE**

In this step use the dashboard mounting template supplied with the pump.

1 - After inserting the washers, using a 10 mm open end wrench, attach the metal flange to the valve by tightening the 4 M6 nuts on the studs with a torque of 10 Nm (7.4 lb ft).

2 - After placing the plastic flange on the console, attach it to the metal flange using 4 screws M6 x 65 mm, the 4 aluminium spacers, the 4 washers and the 4 M6 nuts. Using a 5 mm allen wrench and a 10 mm open end wrench. Tighten the nuts with a torque of 10 Nm (7.4 lb ft).

3 - Apply plastic closure caps

**WARNING**

Use only self-locking fasteners. If they are removed, it will be necessary to replace them.

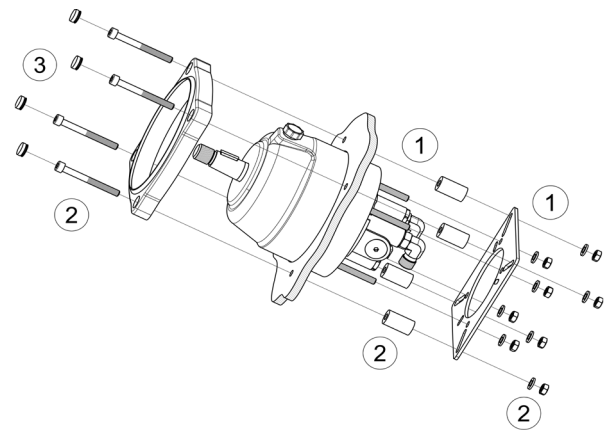

**STEP 4** - Insert the steering wheel into the pump shaft by aligning it with the appropriate key. Insert the washer and use a 24 mm open end wrench. Tighten the self-locking nut with a torque of 40 Nm (29.5 lb ft).

**WARNING**

In this step, before inserting the wheel and screwing the nut, grease the thread and conical part of the pump shaft with high quality marine grease.

**WARNING**

If the self-locking nut is removed when removing the steering wheel, the lock nut must be replaced.

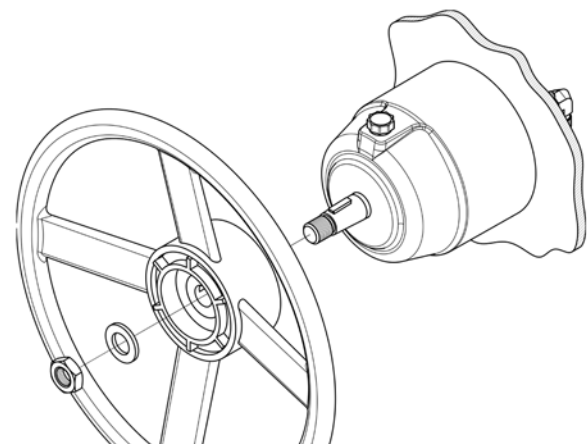



## ■■■ Installation instructions for ORB fittings on GM3 / GM0 / GM2 series steering pump

**STEP 1** - Unscrew and back off lock nut (1), counterclockwise, until it stops as shown in the picture

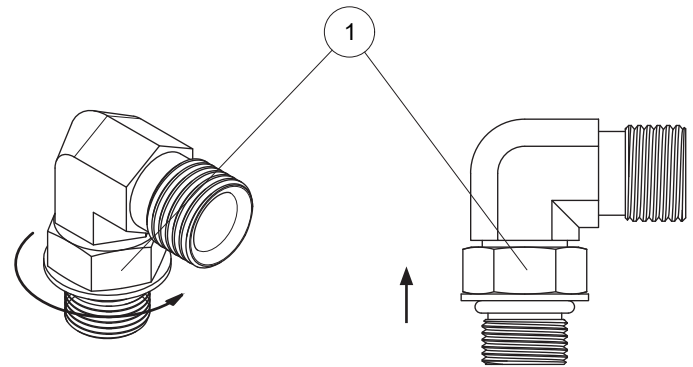

**STEP 2** - Screw the threaded fitting into helm pump holes (2) until fitting washer (3) touches the face of the helm pump holes (4).

### ⚠ WARNING

DON'T USE teflon tape or any type of scotch tape.  
DON'T APPLY any type of sealant such as Loctite 542 or similar.

### ⓘ NOTE

#### VALVE PORTS CONNECTION:

Port marked "C": connections to the cylinder/s.

Port marked "DS": connections to the additional stations or autopilot (use DTN-7x10916 ORB fittings).

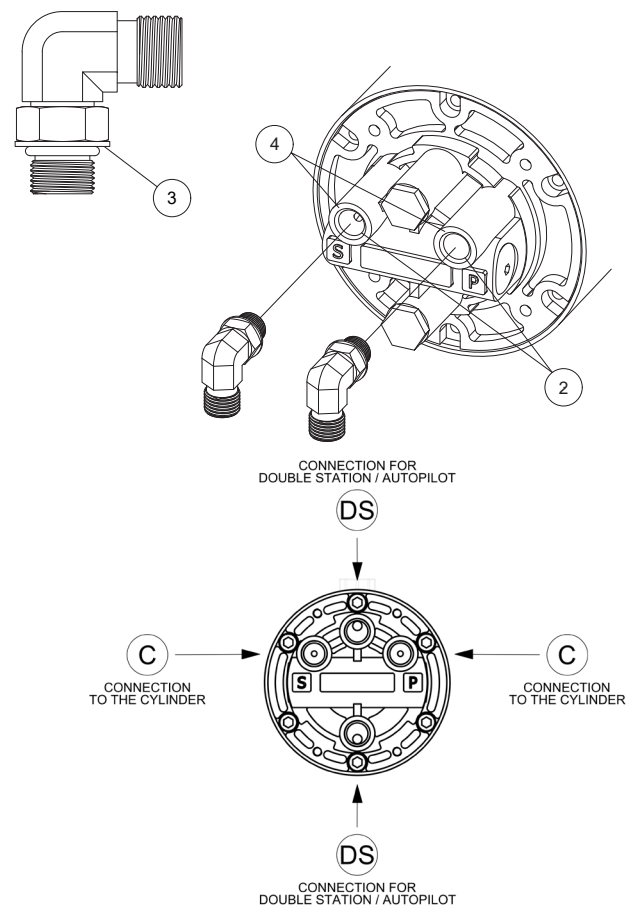

**STEP 3** - Re-position fitting (5) to desire orientation by turning it counter-clockwise to a maximum of 1 full turn. Then, using a 16 mm open end wrench, tighten the locking nuts of the fittings (6) with a torque of 17.6 Nm (13 lb ft).

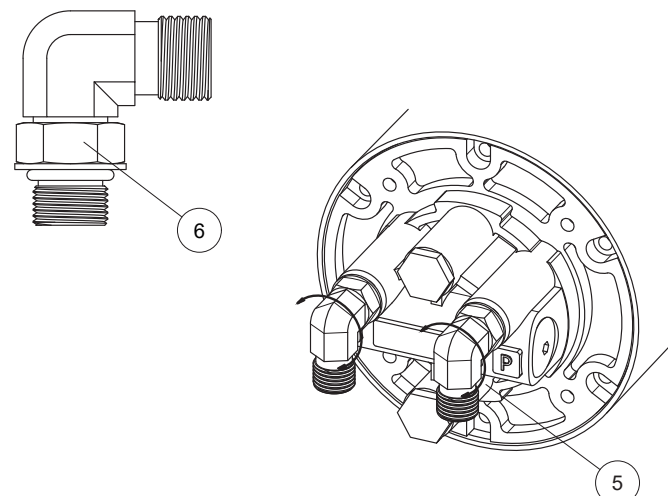

## ■■■ Installation instructions for MC 90B cylinder

### ⚠ WARNING

It is important to check periodically, at least every 3 months (or every month for professional uses), the right torque of this bolt and of the self-locking nut.

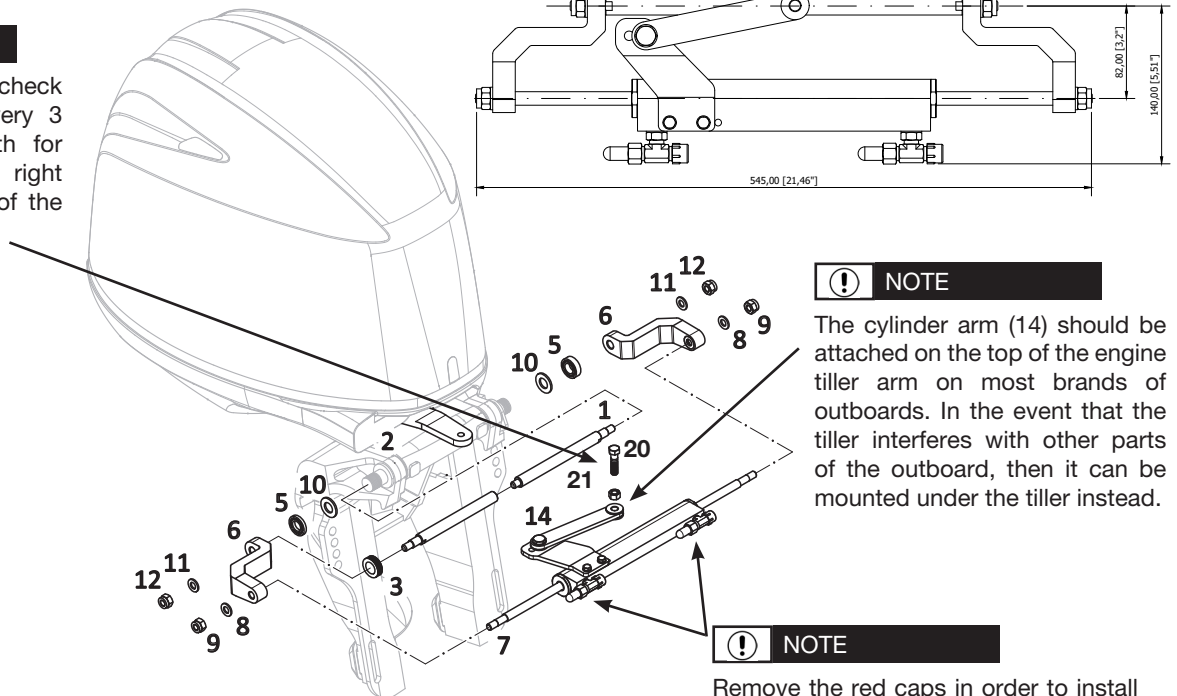

### ⚠ NOTE

The cylinder arm (14) should be attached on the top of the engine tiller arm on most brands of outboards. In the event that the tiller interferes with other parts of the outboard, then it can be mounted under the tiller instead.

### ⚠ NOTE

Remove the red caps in order to install the hose fittings as described on page 34.

REF.	QTY	DESCRIPTION
1	1	Support rod
2	-	Motor tilt tube
3	1	Adjusting nut
5	6	Plastic spacer
6	2	Support brackets

REF.	QTY	DESCRIPTION
7	1	Cylinder
8-11	2+2	Washer
9-12	2+2	Self-locking nut
10	2	Stainless steel washer
20	1	Screw cylinder/ motor arm

Proper cylinder installation is the key to the successful operation of the hydraulic steering system.

### ⚠ WARNING

An incorrectly installed cylinder is subject to rapid seal and bearing wear and non-repairable damage.

### ⚠ WARNING

Protect cylinder shafts from nicks and scratches, which can cause the cylinder to leak, and result in loss of steering.

## Installation steps



- 1 Ensure that the motor tilt tube is perfectly dry and clean, grease the tilt tube rod (1) and make it slide into the tilt tube. Use good-quality grease.
- 2 Completely screw the brass nut (3) to the left threaded side of the tilt tube.
- 3 Grease the end holes of the support brackets (6) and connect them to the tilt tube rod with the cylinder in the middle of its stroke (7).
- 4 After placing the washers (8) using both 17 mm open end wrenches screw the self-locking nuts (9) until they reach the end of the stroke.

### ⚠ NOTE

Tighten the nuts with sufficient force to make them reach the end of the stroke. The final tightening will be performed later.

- 5 Ensure that the cylinder body is centered on the rod (7) and that the engine is perpendicular to the transom. Adjust the link arm length to meet the connection to the motor. Connect the link arm to the motor.
- 6 Connect the link arm (14) to the motor arm using a 14 mm open end wrench, tighten the screw (20) with a torque of 30 Nm (22.1 lb ft). Screw the self-locking nut (21) with a 14 mm open end wrench and tighten it with a torque of 25 Nm (18.5 lb ft). Then, check again the torque applied to the screw (20).

### ⚠ WARNING

The maximum torque to be applied in this step is indicative, so it is advisable to refer to your mechanic in relation to what is the maximum torque allowed. If the torque is lower than that indicated in this manual, tighten with the torque indicated by the mechanic.



- 7 Control the space between motor tilt tube (2) and support brackets (6) whether on the left or on the right of the motor tilt tube; then compensate the gap for expansion by adding a combination of plastic spacers (5).

**⚠ WARNING**

Always leave a minimum clearance between spacers and brackets in order to allow the rod tilting in the tilt tube between motor tilt tube (on the right side) and first spacer put a stainless-steel washer (10).

- 8 Make sure that the brackets completely enter in their housing on the tilt tube rod (1) without being obstructed by the spacers.  
9 Using both 17 mm open end wrenches, tighten the self-locking nuts (9) with a torque of 35 Nm (25.8 lb ft)  
10 After placing the washers (11) using both 17 mm open end wrenches, tighten the self-locking nuts (12) with a torque of 35 Nm (25.8 lb ft).

**⚠ WARNING**

Do not overtighten the self-locking nuts (12). In fact, this may result in the fixing of the support brackets (6) against the motor tilt tube (2), whereas they should be free to turn when you tilt the engine. Failing to observe this warning may cause problems when you tilt the engine.

- 11 Unscrew the brass nut (3) in order to balance the remaining clearance and tighten the brass nut (3). Using a 3 mm allen wrench tighten the pin with a torque of 3 Nm (2 lb ft).

**⚠ WARNING**

Do not use any type of wrench on the adjusting ring nut. Tight it by hand only.

- 12 Check once again the fastening of all the self-locking nuts which however must not obstruct the turnover of the motor and its oscillation.

**⚠ WARNING**

Make sure that the motor can turn side to side without any interference.

**⚠ WARNING**

Check that all mechanical parts of the cylinders are not in contact with the motor and are not strained in their movement.

**⚠ DANGER**

All the systems are not intended for racing boat application.

- 13 Using both 16 mm and 19 mm open end wrenches, screw the hoses on the cylinder fittings with a tightening torque of 20 Nm (15 lb ft).

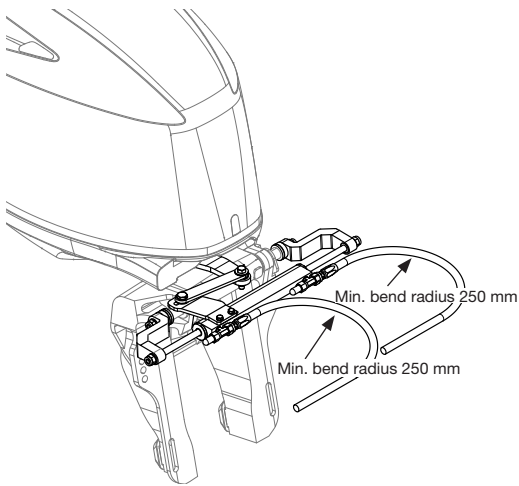

**⚠ WARNING**

Hoses must not go directly onto the cylinder from the bulkhead rubber, but must be left loose so as to make them curve smoothly before reaching the cylinder.

**⚠ WARNING**

Check that hoses don't interfere with the transom even during the engine tilting.

**⚠ WARNING**

Make sure that the hoses bend radius is never less than 250 mm. Excessive bending may damage the hose and result in a malfunction of the hydraulic system. In case of damage, it will be necessary to proceed with the replacement of the hose.

**ⓘ NOTE**

Use Kit X.342 for Yamaha/Tohatsu 40/50/60/70 engine.

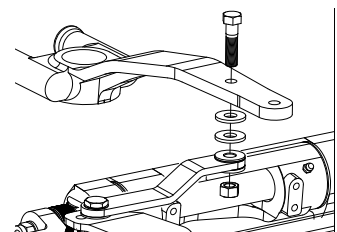
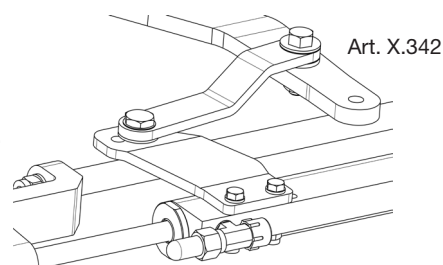

**ⓘ NOTE**

With some motors, the stainless-steel lever of the cylinder must be installed under the engine tiller plate with the addition of some washers.

## ■■■ Installation instructions for MC 150BR cylinder

### ⚠ WARNING

It is important to check periodically, at least every 3 months (or every month for professional uses), the right torque of this bolt and of the self-locking nut.

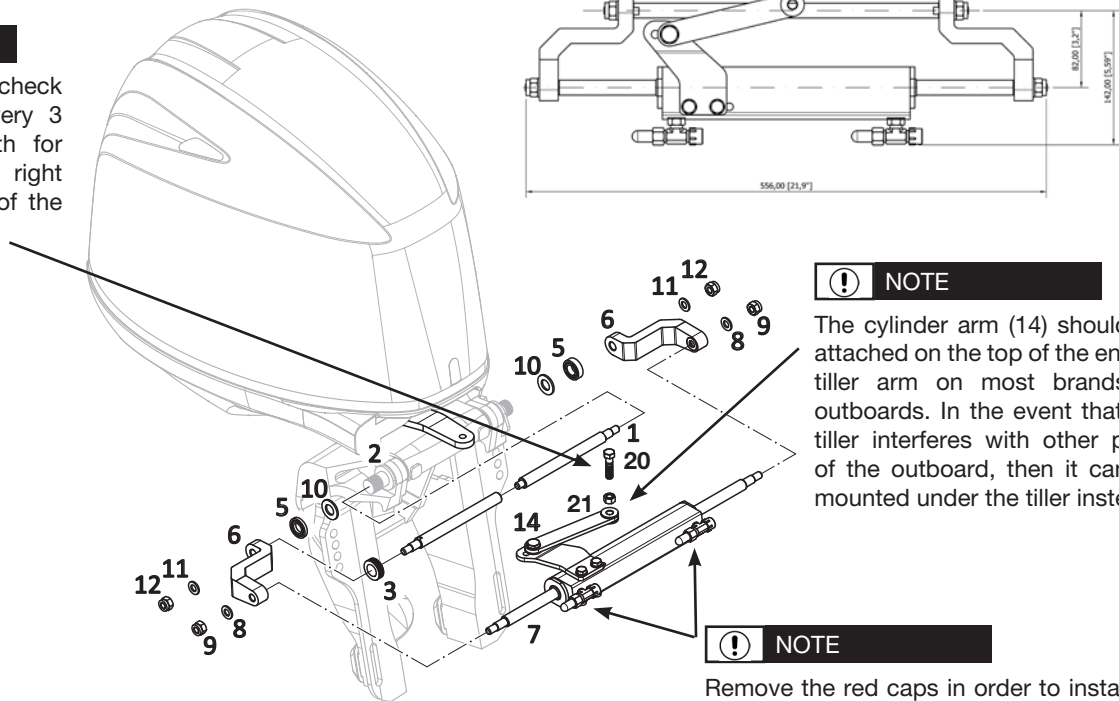

### ⓘ NOTE

The cylinder arm (14) should be attached on the top of the engine tiller arm on most brands of outboards. In the event that the tiller interferes with other parts of the outboard, then it can be mounted under the tiller instead.

### ⓘ NOTE

Remove the red caps in order to install the hose fittings as described on page 34.

REF.	QTY	DESCRIPTION
1	1	Support rod
2	-	Motor tilt tube
3	1	Adjusting nut
5	6	Plastic spacer
6	2	Support brackets

REF.	QTY	DESCRIPTION
7	1	Cylinder
8-11	2+2	Washer
9-12	2+2	Self-locking nut
10	2	Stainless steel washer
20	1	Screw cylinder/ motor arm

Proper cylinder installation is the key to the successful operation of the hydraulic steering system.

### ⚠ WARNING

An incorrectly installed cylinder is subject to rapid seal and bearing wear and non-repairable damage.

### ⚠ WARNING

Protect cylinder shafts from nicks and scratches, which can cause the cylinder to leak, and result in loss of steering.

## Installation steps



- 1 Ensure that the motor tilt tube is perfectly dry and clean, grease the tilt tube rod (1) and make it slide into the tilt tube. Use good-quality grease.
- 2 Completely screw the brass nut (3) to the left threaded side of the tilt tube.
- 3 Grease the end holes of the support brackets (6) and connect them to the tilt tube rod with the cylinder in the middle of its stroke (7).
- 4 After placing the washers (8), using both 17 mm open end wrenches, screw the self-locking nuts (9) until they reach the end of the stroke.

### ⓘ NOTE

Tighten the nuts with sufficient force to make them reach the end of the stroke. The final tightening will be performed later.

- 5 Ensure that the cylinder body is centered on the rod (7) and that the engine is perpendicular to the transom. Adjust the link arm length to meet the connection to the motor. Connect the link arm to the motor.
- 6 Connect the link arm (14) to the motor arm, using a 14 mm open end wrench, tighten the screw (20) with a torque of 40 Nm (29.5 lb ft). Screw the self-locking nut (21) with a 14 mm open end wrench and tighten it with a torque of 25 Nm (18.5 lb ft). Then, check again the torque applied to the screw (20).

### ⚠ WARNING

The maximum torque to be applied in this step is indicative, so it is advisable to refer to your mechanic in relation to what is the maximum torque allowed. If the torque is lower than that indicated in this manual, tighten with the torque indicated by the mechanic.

- 7 Control the space between motor tilt tube (2) and support brackets (6) whether on the left or on the right of the motor tilt tube; then compensate the gap for expansion by adding a combination of plastic spacers (5).

**⚠ WARNING**

Always leave a minimum clearance between spacers and brackets in order to allow the rod tilting in the tilt tube between motor tilt tube (on the right side) and first spacer put a stainless-steel washer (10).

- 8 Make sure that the brackets completely enter in their housing on the tilt tube rod (1) without being obstructed by the spacers.  
9 Using both 17 mm open end wrenches, tighten the self-locking nuts (9) with a torque of 60 Nm (44 lb ft).  
10 After placing the washers (11), using both 17 mm open end wrenches, tighten the self-locking nuts (12) with a torque of 70 Nm (52 lb ft).

**⚠ WARNING**

Do not over tighten the self-locking nuts (12). In fact, this may result in the fixing of the support brackets (6) against the motor tilt tube (2), whereas they should be free to turn when you tilt the engine. Failing to observe this warning may cause problems when you tilt the engine.

- 11 Unscrew the brass nut (3) in order to balance the remaining clearance and tighten the brass nut (3). Using a 3 mm allen wrench tighten the pin with a torque of 3 Nm (2 lb ft).

**⚠ WARNING**

Do not use any type of wrench on the adjusting ring nut. Tight it by hand only.

- 12 Check once again the fastening of all the self-locking nuts which however must not obstruct the turnover of the motor and its oscillation.

**⚠ WARNING**

Make sure that the motor can turn side to side without any interference.

**⚠ WARNING**

Check that all mechanical parts of the cylinders are not in contact with the motor and are not strained in their movement.

**⚠ DANGER**

All the systems are not intended for racing boat application.

- 13 Using both 16 mm and 19 mm open end wrenches, screw the tubes on the cylinder fittings with a tightening torque of 20 Nm (15 lb ft).

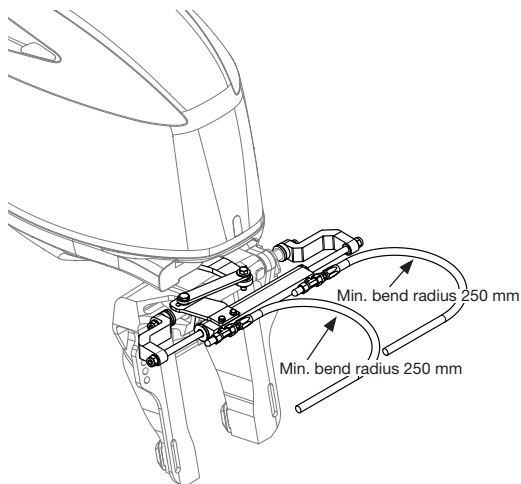

**⚠ WARNING**

Hoses must not go directly onto the cylinder from the bulkhead rubber, but must be left loose so as to make them curve smoothly before reaching the cylinder.

**⚠ WARNING**

Check that hoses don't interfere with the transom even during the engine tilting.

**⚠ WARNING**

Make sure that the hoses bend radius is never less than 250 mm. Excessive bending may damage the hose and result in a malfunction of the hydraulic system. In case of damage, it will be necessary to proceed with the replacement of the hose.

**ⓘ NOTE**

Use Kit X.342 for Yamaha/Tohatsu 40/50/60/70, Mercury Optimax 90/115 e Honda 115/130 HP engine.

**ⓘ NOTE**

With some motors, the stainless-steel lever of the cylinder must be installed under the engine tiller plate with the addition of some washers.

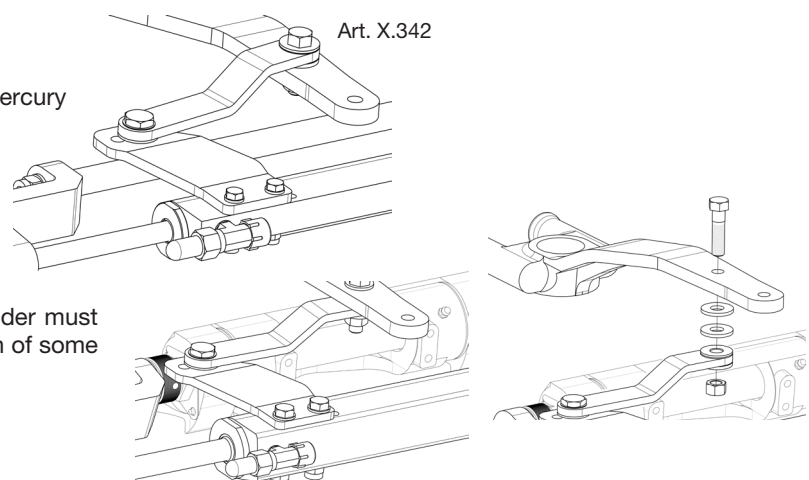

■■■ Installation instructions for MC 150 cylinder

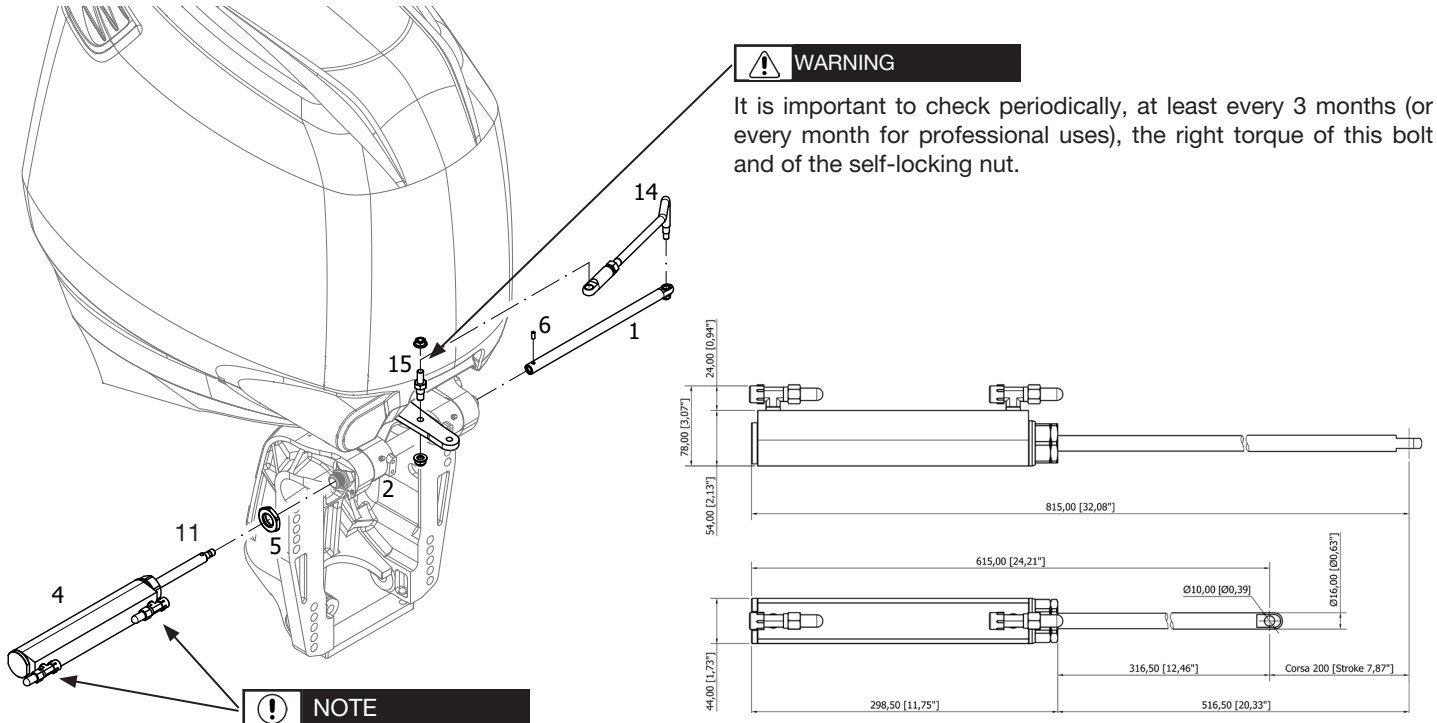

**WARNING**

It is important to check periodically, at least every 3 months (or every month for professional uses), the right torque of this bolt and of the self-locking nut.

**NOTE**

Remove the red caps in order to install the hose fittings as described on page 34.

REF.	QTY	DESCRIPTION
1	1	Extension rod
2	-	Motor tilt tube
4	1	Cylinder
5	-	Adjusting nut
6	1	Pin
14(*)	1	Tiller arm *
15	1	Screw, washer, self-locking nut

**NOTE**

(\*) The tiller arm is not supplied

Proper cylinder installation is the key to the successful operation of the hydraulic steering system.

**WARNING**

An incorrectly installed cylinder is subject to rapid seal and bearing wear and non-repairable damage.

**WARNING**

Protect cylinder rods from nicks and scratches, which can cause cylinder to leak, and result in loss of steering.



**Installation steps**

- 1 Ensure that the motor tilt tube is perfectly dry and clean. Screw the cylinder nut (5) to the end of the threaded part on the left side of the engine boat.
- 2 Grease the extension rod (1) with good-quality marine grease. Insert the extension rod on left side of motor tilt tube.
- 3 Using the locking hole (11) on the cylinder rod, screw the extension rod (1) onto the cylinder shaft until it reaches the end. Using a 2.5 mm allen wrench, fix it with the pin (6).
- 4 Screw the cylinder to the left threaded side of motor tilt tube, keeping the bleeders on the upper side of the cylinder. Using both 38 mm open end wrenches, tighten the adjusting-nut (5) against the cylinder with a torque of 40 Nm (29.5 lb ft).
- 5 Connect the tiller arm (14) to the extension rod as shown in the picture.
- 6 Put the cylinder and the motor in middle of its stroke, and adjust the tiller arm distance. Connect the tiller arm to the motor with screw, washer and self-locking nut (15).

**WARNING**

For the tightening torques during the assembly of the tiller arm, refer to the manufacturer's instructions.

**DANGER**

All the systems are not intended for racing boat application.

## ■■■ Installation instructions for MC 150R / MC 300R cylinder

### ⚠ WARNING

It is important to check periodically, at least every 3 months (or every month for professional uses), the right torque of this bolt and of the self-locking nut.

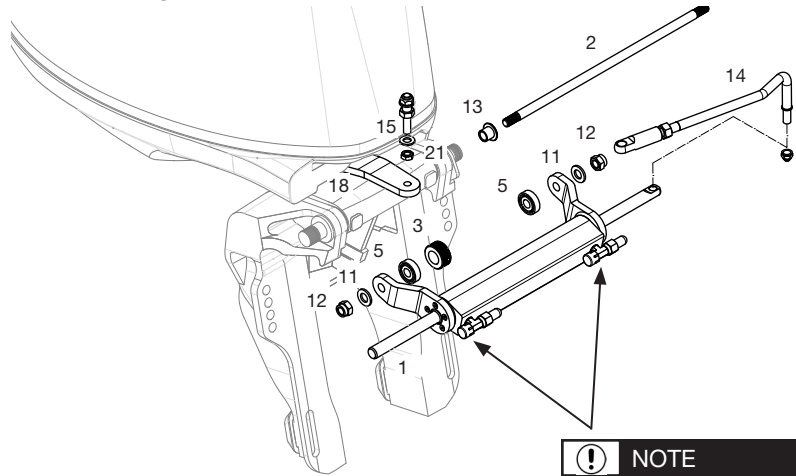
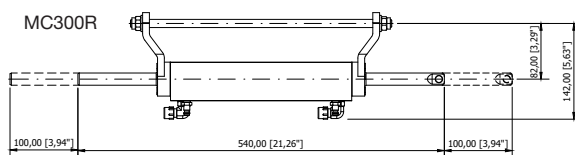
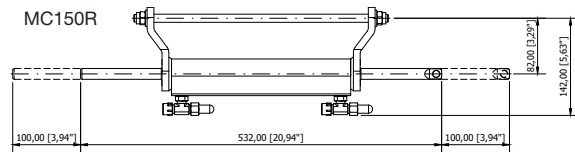

### ⚠ NOTE

Remove the red caps in order to install the hose fittings as described on page 34.

REF.	QTY	DESCRIPTION
2	1	Support rod
18	-	Motor tilt tube
3	1	Adjusting nut
5	6	Plastic spacer
13	1	Inox bushing

REF.	QTY	DESCRIPTION
1	1	Cylinder
11	2	Washer
12	2	Self-locking nut
14	1	Tiller arm
15	1	Screw, washer, self-locking nut

Proper cylinder installation is the key to the successful operation of the hydraulic steering system.

### ⚠ WARNING

An incorrectly installed cylinder is subject to rapid seal and bearing wear and non-repairable damage.

### ⚠ WARNING

Protect cylinder shafts from nicks and scratches, which can cause the cylinder to leak, and result in loss of steering.

## Installation steps

- 1 Ensure that the motor tilt tube (18) is perfectly dry and clean. Completely screw the brass nut (3) to left threaded side of the tilt tube and put the bushing (13) into the right threaded part of the tilt tube.
- 2 Grease the tilt tube rod (2) with good-quality grease. Put the cylinder (1) in front of the motor tilt tube (18) and insert the tilt tube rod (2) starting from the right side.
- 3 Control the space between motor tilt tube (18) and support brackets of the cylinder whether on the left or on the right of the motor tilt tube; then, compensate the gap for expansion adding a combination of plastic spacers (5).
- 4 After placing the washers (11), using both 17 mm open end wrenches, tighten the self-locking nuts (12) with a torque of 70 Nm (52 lb ft).

### ⚠ WARNING

Do not over tighten the self-locking nuts (12). In fact, this may imply the fixing of the support brackets (6) against the motor tilt tube (2), whereas they should be free to turn when you tilt the engine. Failing to observe this warning may cause problems when you tilt the engine.

- 5 Unscrew the brass nut (3) in order to balance the remaining clearance and tighten the brass nut (3). Using a 3 mm allen wrench, tighten the pin with a torque of 3 Nm (2 lb ft).

### ⚠ WARNING

Do not use any type of wrench on the adjusting ring nut. Tight it by hand only.

- 6 Place the shaft of the cylinder in the middle of its stroke.
- 7 Connect the tiller arm (14) to the connecting rod's right side, using 13 mm open end wrench, tighten the self-locking nuts with screw and washer.
- 8 Put the cylinder and the motor in the middle of its stroke, and adjust the tiller arm distance. Connect the tiller arm to the motor using a 14 mm open end wrench. Tighten the screw (15) with a torque of 54 Nm (40 lb ft). Screw the self-locking nut (21) with a 14 mm open end wrench and tighten it with a torque of 27 Nm (20 lb ft). Then, check again the torque applied to the screw (15).

### ⚠ WARNING

The maximum torque to be applied in this step is indicative, so it is advisable to refer to your mechanic in relation to what is the maximum torque allowed. If the torque is lower than that indicated in this manual, tighten with the torque indicated by the mechanic.

- 9 Check once again the fastening of all the self-locking nuts which however must not obstruct the turnover of the motor and its oscillation.

### ⚠ WARNING

Make sure that the motor can turn side to side without any interference.

### ⚠ WARNING

Check that all mechanical parts of the cylinders are not in contact with the motor and are not strained in their movement.

### ⚠ DANGER

All the systems are not intended for racing boat application.



■■■ Installation instructions for MC 300BHD Evolution cylinder

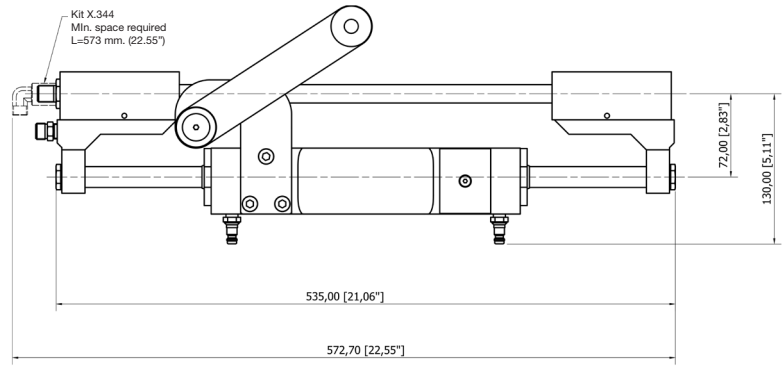
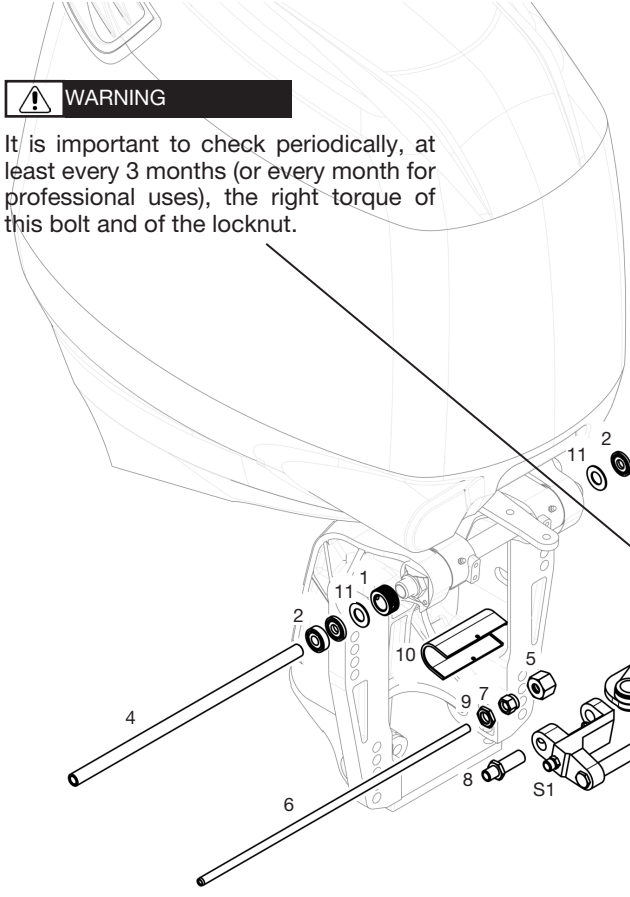

**NOTE**  
The cylinder's stainless-steel lever should be attached on the top of the engine tiller arm on most brands of outboards. In the event that the stainless-steel lever interferes with other parts of the outboard, then it can be mounted under the tiller arm.

REF.	QTY	DESCRIPTION
1	1	Adjusting nut
S1	1	Left support bracket
S2	1	Right support bracket
2	6	Spacer
3	1	Cylinder
4	1	Ø 15,9 rod
5	2	Hexagonal nut 27 mm

REF.	QTY	DESCRIPTION
6	1	Feeding oil rod
7	1	Hexagonal nut 19 mm
8	1	Fitting
9	1	Hexagonal nut 22 mm
10	2	Plastic cover
11	2	S.s. washer
12-13	1	Screw 3/8" + nut 3/8"

Proper cylinder installation is the key to the successful operation of the hydraulic steering system.

**WARNING**

An incorrectly-installed cylinder is subject to rapid seal and bearing wear and non-repairable damage.

**WARNING**

Protect cylinder shafts from nicks and scratches, which can cause cylinder to leak, and result in loss of steering.

**DANGER**

All the systems are not intended for racing boat application.



## Installation steps

### STEP 1

- A) Connect the link arm (14) to the motor arm using a 14 mm open end wrench. After place the washer (13), tighten the screw (15) with a torque of 54 Nm (40 lb ft). Screw the self-locking nut (15) with a 14 mm open end wrench and tighten it with a torque of 27 Nm (20 lb ft). Then, check again the torque applied to the screw (12).

#### WARNING

The maximum torque to be applied in this step is indicative, so it is advisable to refer to your mechanic in relation to what is the maximum torque allowed. If the torque is lower than that indicated in this manual, tighten with the torque indicated by the mechanic.

- B) Completely screw the brass nut (1) to the left threaded side of the tilt tube.

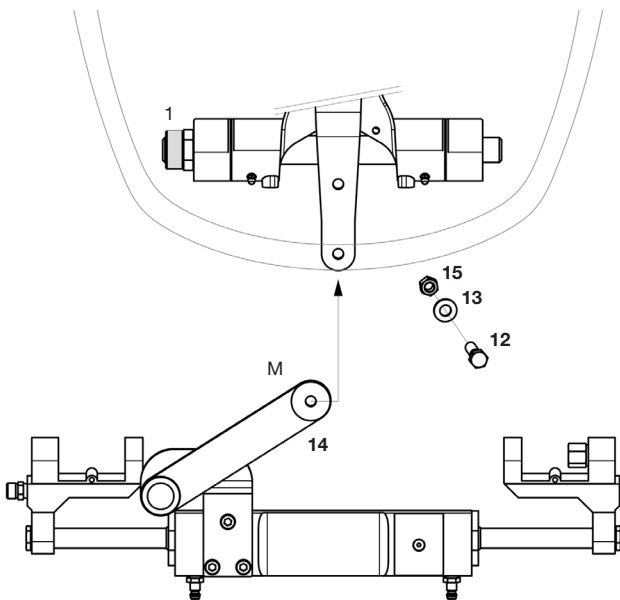

### STEP 2

- A) Ensure that the cylinder body is centered on the rod and that the engine is perpendicular to the transom.
- B) Check the space "x" between the support brackets (S1 - S2) and the motor tilt tube; then compensate it by adding a combination of plastic spacers (2) and 1 washer (11) for each side. (If needed). Making sure that the motor and the cylinder are in a central position.
- C) Put the rod (4) through the holes of the left support bracket (S1) and slide it into the motor tilt tube, so in the holes of the right support bracket (S2). Block it using the nuts (5). Using 27 mm open end wrench, tighten the nuts (5) with a torque of 40 Nm (29.5 lb ft).
- D) After having inserted the rod (4) into the motor tilt tube, check that it is perfectly clean and there are no impurities inside of it.
- E) Unscrew the regulation nuts (1) in order to eliminate the clearance, avoiding to block the supports (S1 - S2) to the motor tilt tube. Ensure that the motor and the cylinder are free to rotate on their own axis. Then lock the ring nut. Using a 3 mm allen wrench tighten the pin with a torque of 3 Nm (2 lb ft).

#### WARNING

Do not use any type of wrench on the adjusting ring nut. Tight it by hand only.

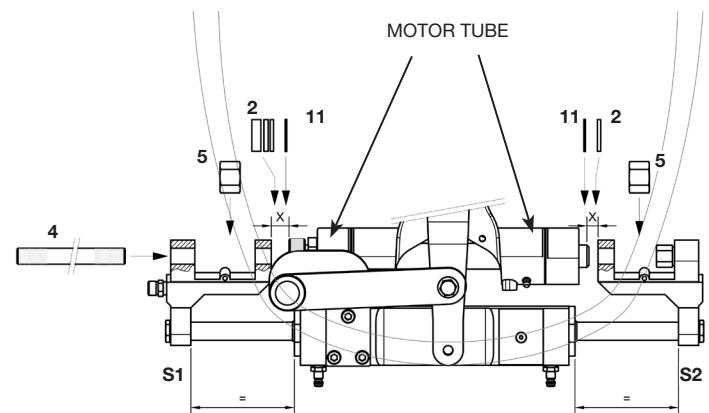

### STEP 3

- A) Introduce the feeding rod (6) in the "Z" hole and put the nut (7) on the rod [Picture A], then complete the connection up to the fitting (R) after having removed the plastic protection placed on the fitting.

#### NOTE

Before completing the connection, lubricate the rod (6) and ensure that the internal hole of the rod is clean and without impurities.

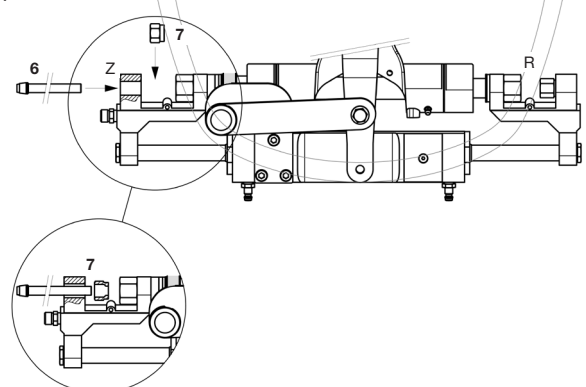

**STEP 4**

- A) Put the fitting (8) into the “Z” hole of the left support bracket.
- B) As soon as the fitting (8) has passed the hole (Z), insert the washer and screw the nut (9) on it.

**⚠ WARNING**

In this step, don't lock the nut (9) with the fitting (8).

- C) Using both a 22 mm and a 19 mm open end wrenches, tighten the nut (7) [Picture B] with a torque of 30 Nm (22.1 lb ft).
- D) Using both 22 mm open end wrenches, tighten the nut (9) with the fitting (8) [Picture B] with a torque of 30 Nm (22.1 lb ft).

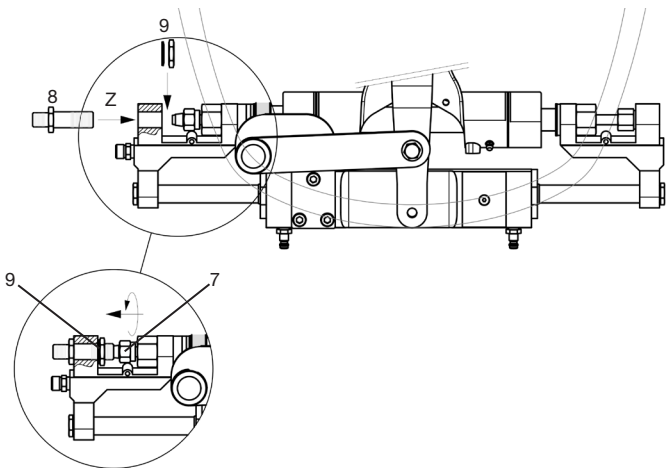

Installation instructions kit. X.344 see section below.

**STEP 5**

- A) Insert the covers (10) on the support brackets.
- B) Screw the screws on the covers tightening them on the support brackets.

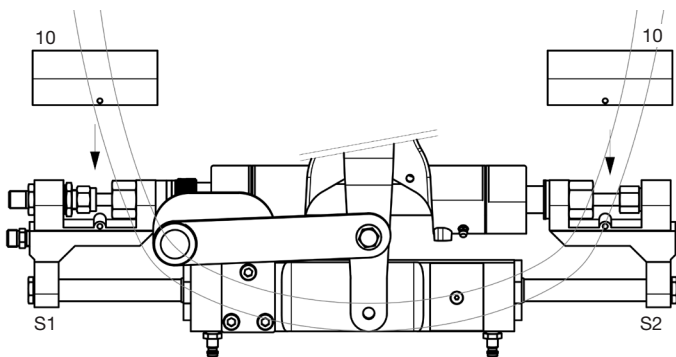

**■■■ Installation instructions for X.344 kit**

If interference is present between the end of the steering cylinder and the motor well wall and there is not enough clearance sideways for the hoses, it could be eliminated with Kit X.344 90° fittings.

Straight fitting must be substituted with elbow fitting. Use a pipe sealant such as Loctite 577 or equivalent on 1/4NPT thread fittings.

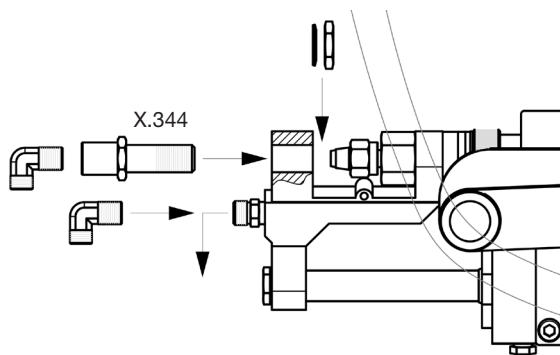

**STEP 6**

- A) Connect the hoses as shown in this illustration.

**⚠ NOTE**

In order to simplify this operation, it is better to mark both ends of one hose before proceeding with the installation.

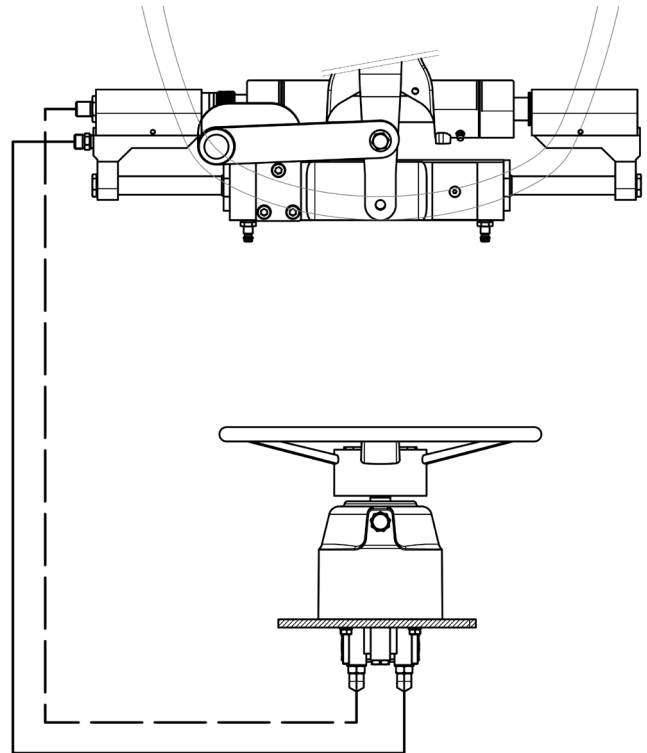

**⚠ WARNING**

Check that hoses don't interfere with the transom even during the engine tilting.

**⚠ WARNING**

Make sure that the hoses bend radius is never less than 250 mm. Excessive bending may damage the hose and result in a malfunction of the hydraulic system. In case of damage, it will be necessary to proceed with the replacement of the hose.



## ■■■ Ground strap installation instructions for MC 300BHD cylinder

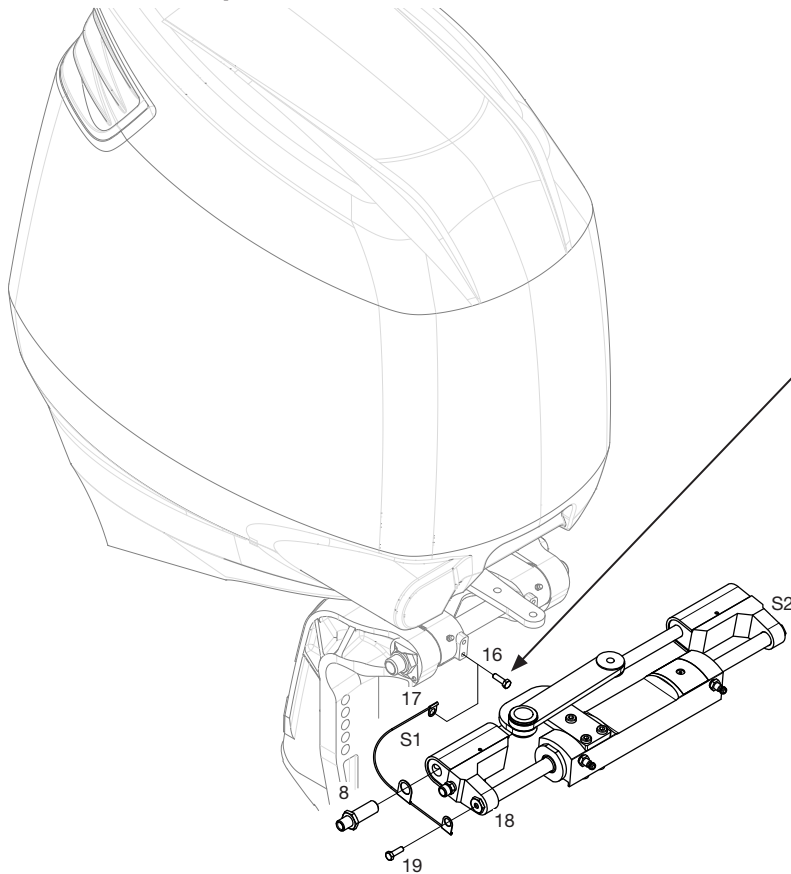

### ! NOTE

#### **YAMAHA:**

use M6x1.0 fasteners (included in kit)

#### **EVINRUDE:**

use fasteners already installed in steering bracket holes

#### **All others:**

use 1/4"-28 fasteners (included in kit)

Notice for salt water applications

### ! NOTE

**MAVIMARE** strongly recommends use of a ground strap on any outboard hydraulic steering cylinder with an exposed shaft where the vessel will be used in salt water. This ground strap will provide added protection against corrosion caused by stray current.



## Installation steps

- 1 Attach end terminal (17) to the starboard side lower midsection steering bracket hole (wire facing downwards) using the correct fasteners (16).
- 2 Route ground strap UNDER the tilt tube. Install ground strap loose and terminal to cylinder as shown in picture.
- 3 Attach the small terminal using the screw (19) on unused threaded hole (18) in rear of cylinder support bracket.
- 4 Attach middle terminal between fittings (8) and the support bracket (S1). Orient terminal as shown in picture.

### ! WARNING

Ensure there is enough slack in the strap to allow the engine to pivot freely in ALL trim/tilt positions and throughout the entire steering range of the engine.

### ! WARNING

Ensure ground strap is routed 'under' the tilt tube. Installation of the strap 'above' the tilt tube may lead to a hang up, or restriction.

■■■ Double cylinder MC 300BHD installation scheme

Diagram A

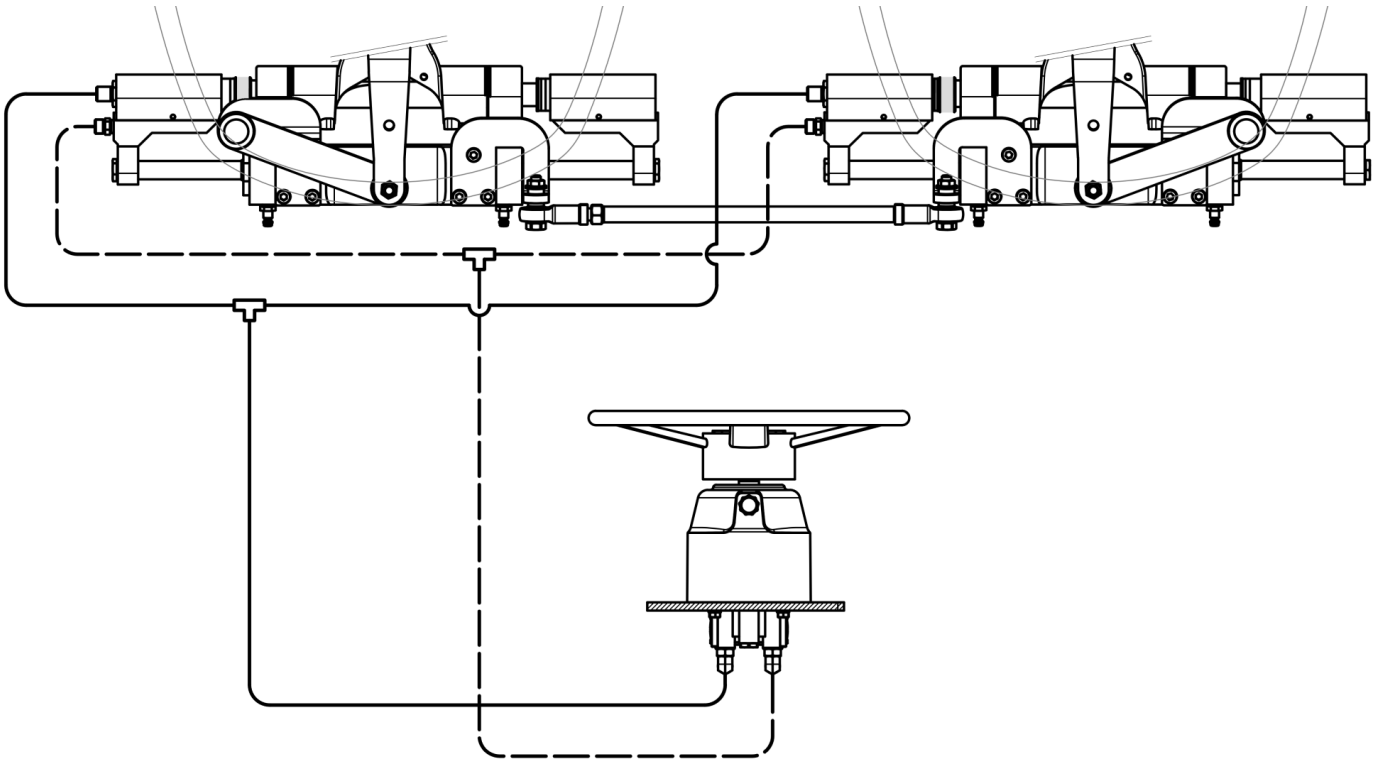
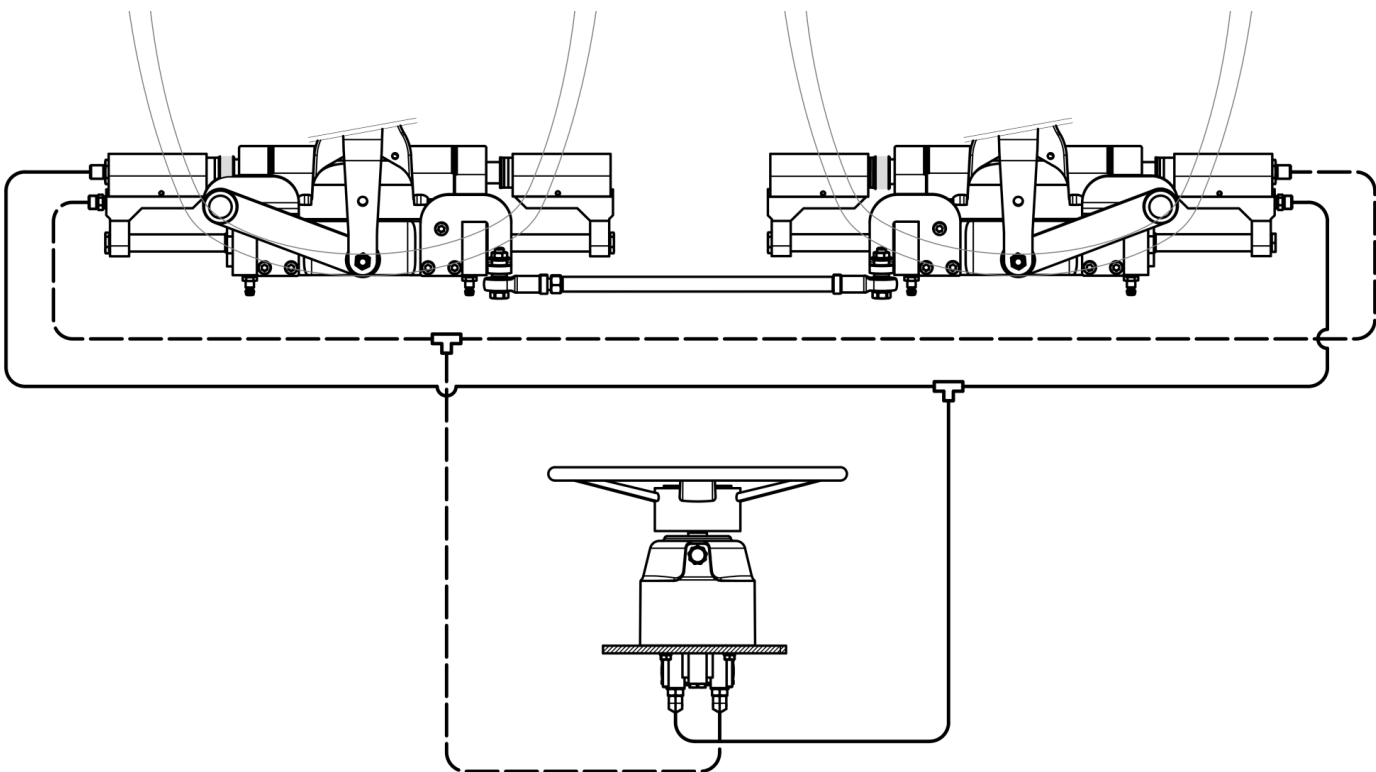

Diagram B



## ■■■ Installation instructions for MC 300HD - MC 350HD cylinder

### NOTE

The cylinder's stainless-steel lever should be attached on the top of the engine tiller arm on most brands of outboards. In the event that the stainless-steel lever interferes with other parts of the outboard, then it can be mounted under the tiller arm.

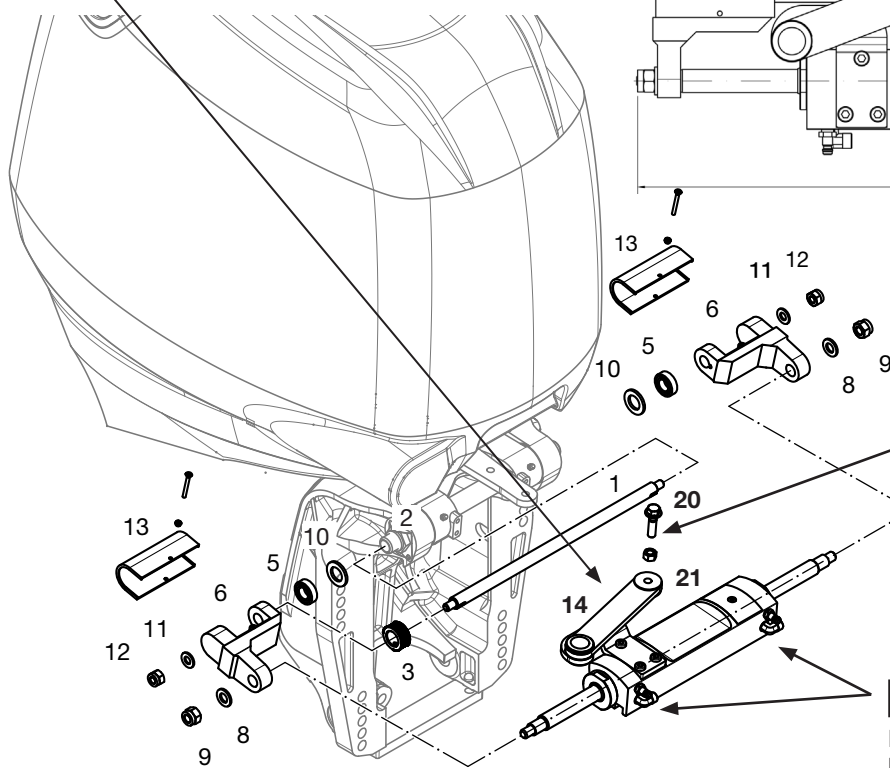
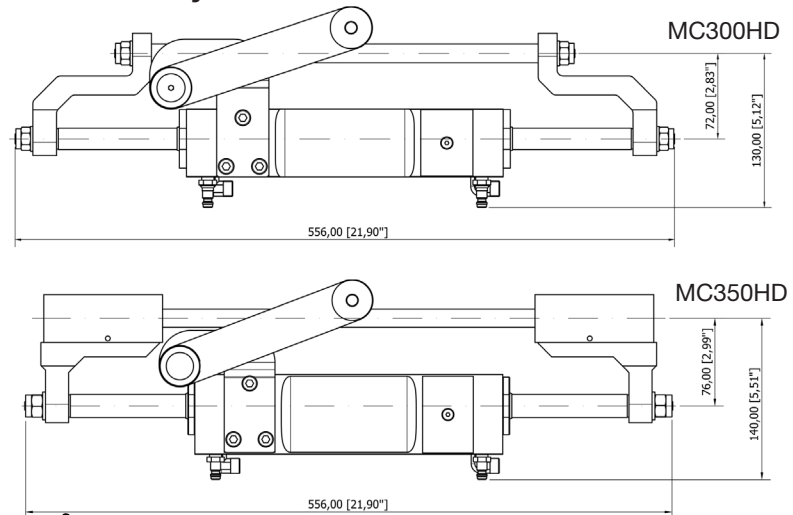

### WARNING

It is important to check periodically, at least every 3 months (or every month for professional uses), the right torque of this bolt and of the locknut.

### NOTE

Remove the red caps in order to install the hose fittings as described on page 34.

REF.	QTY	DESCRIPTION
1	1	Support rod
2	-	Motor tilt tube
3	1	Adjusting nut
5	6	Plastic spacer
6	2	Support brackets

REF.	QTY	DESCRIPTION
7	1	Cylinder
8-11	2+2	Washer
9-12	2+2	Self-locking nut
10	2	Stainless steel washer
13	2	Plastic cover

Proper cylinder installation is the key to the successful operation of the hydraulic steering system.

### WARNING

An incorrectly-installed cylinder is subject to rapid seal and bearing wear and non-repairable damage.

### WARNING

Protect cylinder shafts from nicks and scratches, which can cause cylinder to leak, and result in loss of steering.

## Installation steps



- 1 Ensure that the motor tilt tube is perfectly dry and clean, grease the tilt tube rod (1) and make it slide into the tilt tube. Use good-quality grease.
- 2 Completely screw the brass nut (3) to the left threaded side of the tilt tube.
- 3 Grease the end holes of the support brackets (6) and connect them to the tilt tube rod with the cylinder in the middle of its stroke (7).
- 4 After placing the washers (8), using both 17 mm (MC 300HD) / 19 mm (MC 350HD) open end wrenches, screw the self-locking nuts (9) until they reach the end of the stroke.

### NOTE

Tighten the nuts with sufficient force to make them reach the end of the stroke. The final tightening will be performed later.

- 5 Ensure that the cylinder body is centered on the rod (7) and that the engine is perpendicular to the transom. Adjust the link arm length to meet the connection to the motor. Connect the link arm to the motor, making sure that the motor and the cylinder are in a central position.
- 6 Connect the link arm (14) to the motor arm using a 14 mm open end wrench. Tighten the screw (20) with a torque of 54 Nm (40 lb ft). Screw the self-locking nut (21) with a 14 mm open end wrench and tighten it with a torque of 27 Nm (20 lb ft). Then, check again the torque applied to the screw (20).

**⚠ WARNING**

The maximum torque to be applied in this step is indicative, so it is advisable to refer to your mechanic in relation to what is the maximum torque allowed. If the torque is lower than that indicated in this manual, tighten with the torque indicated by the mechanic.

- 7 Control the space between motor tilt tube (2) and support brackets (6) whether on the left or on the right of the motor tilt tube; then compensate the gap for expansion by adding a combination of plastic spacers (5).

**⚠ WARNING**

Always leave a minimum clearance between spacers and brackets in order to allow the rod tilting in the tilt tube. Between motor tilt tube (on the right side) and first spacer put a stainless-steel washer (10).

- 8 Make sure that the brackets completely enter in their housing on the tilt tube rod (1) without being obstructed by the spacers.
- 9 Using both 17 mm (MC 300HD) / 19 mm (MC 350HD) open end wrenches tighten the self-locking nuts (9) with a torque of 70 Nm (52 lb ft)
- 10 After placing the washers (11), using both 17 mm open end wrenches, tighten the self-locking nuts (12) with a torque of 70 Nm (52 lb ft).

**⚠ WARNING**

Do not over tighten the self-locking nuts (12). In fact, this may result in the fixing of the support brackets (6) against the motor tilt tube (2), whereas they should be free to turn when you tilt the engine. Failing to observe this warning may cause problems when you tilt the engine.

- 11 Unscrew the brass nut (3) in order to balance the remaining clearance and tighten the brass nut (3). Using a 3 mm allen wrench tighten the pin with a torque of 3 Nm (2 lb ft).

**⚠ WARNING**

Do not use any type of wrench on the adjusting ring nut. Tight it by hand only.

- 12 Check once again the fastening of all the self-locking nuts which however must not obstruct the turnover of the motor and its oscillation.

**⚠ WARNING**

Make sure that the motor can turn side to side without any interference.

**⚠ WARNING**

Check that all mechanical parts of the cylinders are not in contact with the motor and are not strained in their movement.

**In case of MC350HD cylinder installation**

- 13 Insert the covers (10) on the support brackets. Screw the screws on the covers tightening them on the support brackets.

**⚠ DANGER**

All the systems are not intended for racing boat application.

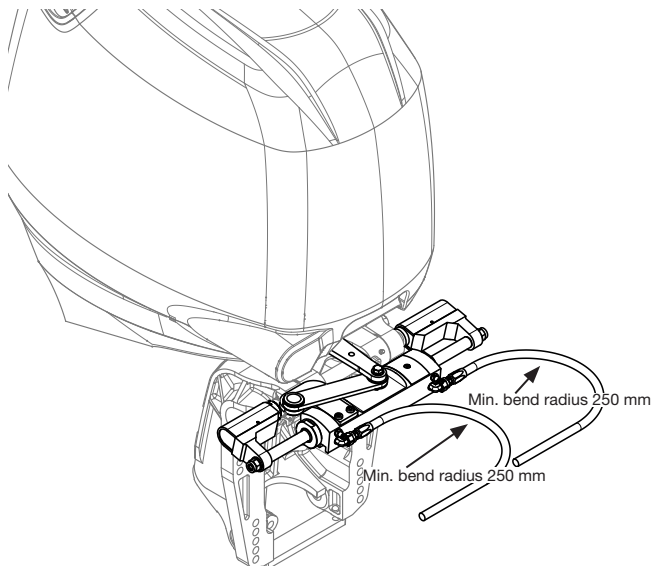

**⚠ WARNING**

Hoses must not go directly onto the cylinder from the bulkhead rubber, but must be left loose so as to make them curve smoothly before reaching the cylinder.

**⚠ WARNING**

Check that hoses don't interfere with the transom even during the engine tilting.

**⚠ WARNING**

Make sure that the hoses bend radius is never less than 250 mm. Excessive bending may damage the hose and result in a malfunction of the hydraulic system.

In case of damage, it will be necessary to proceed with the replacement of the hose.

## ■■■ Ground strap installation instructions for MC 300HD – MC 350HD cylinder

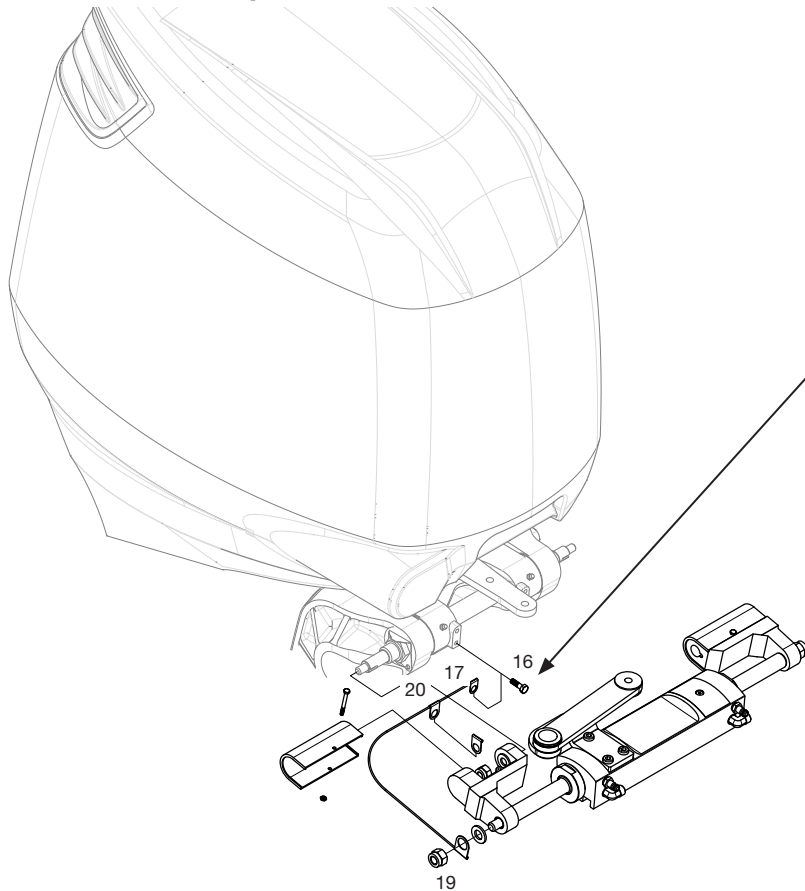

### ! NOTE

#### **YAMAHA:**

use M6x1.0 fasteners (included in kit)

#### **EVINRUDE:**

use fasteners already installed in steering bracket holes

#### **All others:**

use 1/4"-28 fasteners (included in kit)

Notice for salt water applications

### ! NOTE

**MAVIMARE** strongly recommends use of a ground strap on any outboard hydraulic steering cylinder with an exposed shaft where the vessel will be used in salt water. This ground strap will provide added protection against corrosion caused by stray current.



## Installation steps

- 1 Attach end terminal (17) to the starboard side lower midsection steering bracket hole (wire facing downwards) using the correct fasteners (16).
- 2 Route ground strap UNDER the tilt tube. Install ground strap loose and terminal to cylinder as shown in picture.
- 3 Attach the terminal with the cylinder shaft nut (19).
- 4 Attach small middle terminal (20) to unused hole in rear of cylinder support bracket. Orient terminal as shown in picture.

### ! WARNING

Ensure there is enough slack in the strap to allow the engine to pivot freely in ALL trim/tilt positions and throughout the entire steering range of the engine.

### ! WARNING

Ensure ground strap is routed 'under' the tilt tube. Installation of the strap 'above' the tilt tube may lead to a hang up, or restriction.

■■■ Twin engines application with tie bar code 358.00 - 358.06



Installation with single cylinder

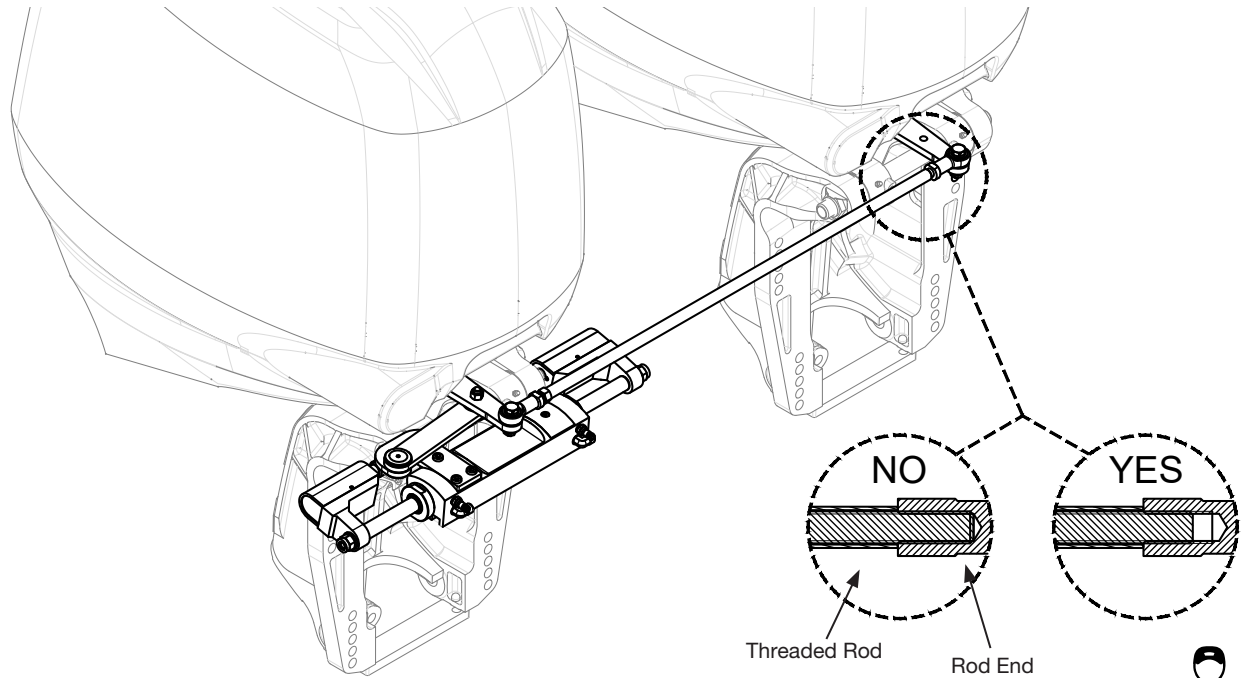

Installation with single cylinder

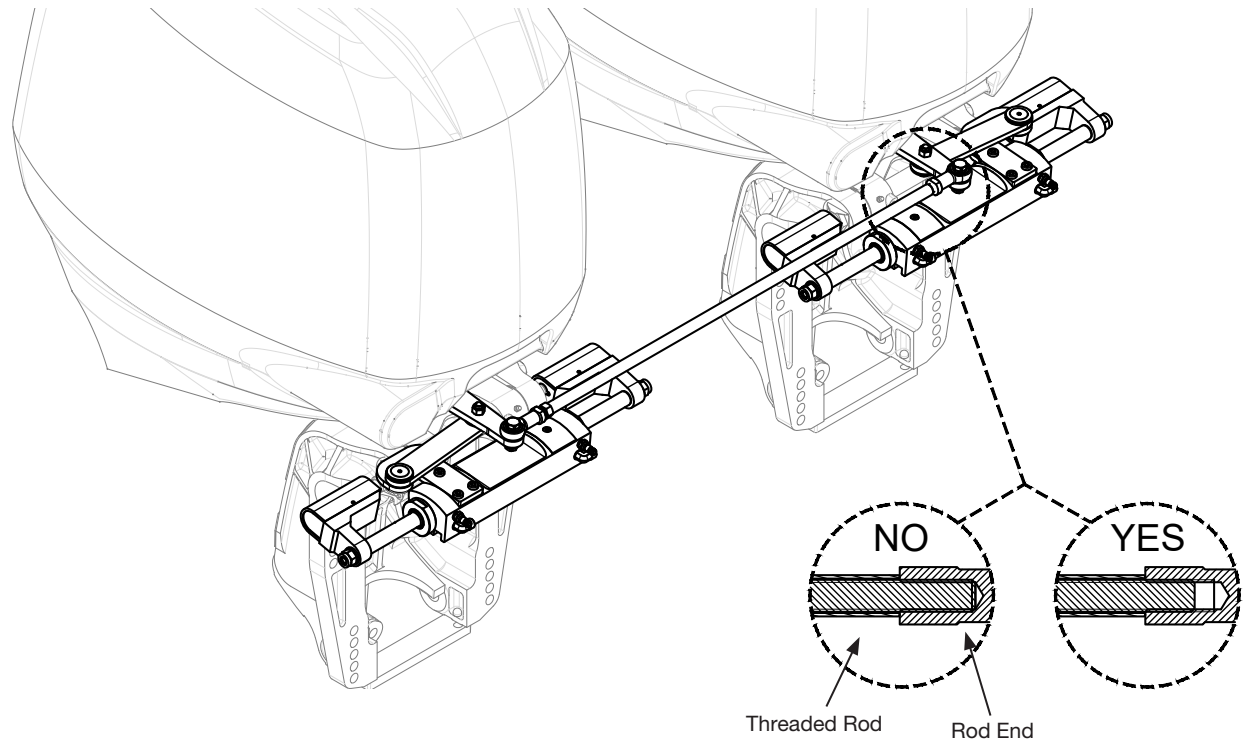

Cut the threaded bar and tube to the length calculated according to the distance of the motors.

**⚠ WARNING**

As the tiller arm position varies from engine to engine and the distance between two engines is not predictable, unexpected interferences may occur while tilting. A duly check of the tie bar installation is then strongly recommended.

**⚠ WARNING**

Do not block the threaded rod against the rod end terminal. The threaded rod should be able to rotate freely. Do not apply Loctite. Failing to observe this warning may result in damage of the tie bar while tilting one of the two engines.

### ■■■ Twin engines installation with tie bar code 358.02

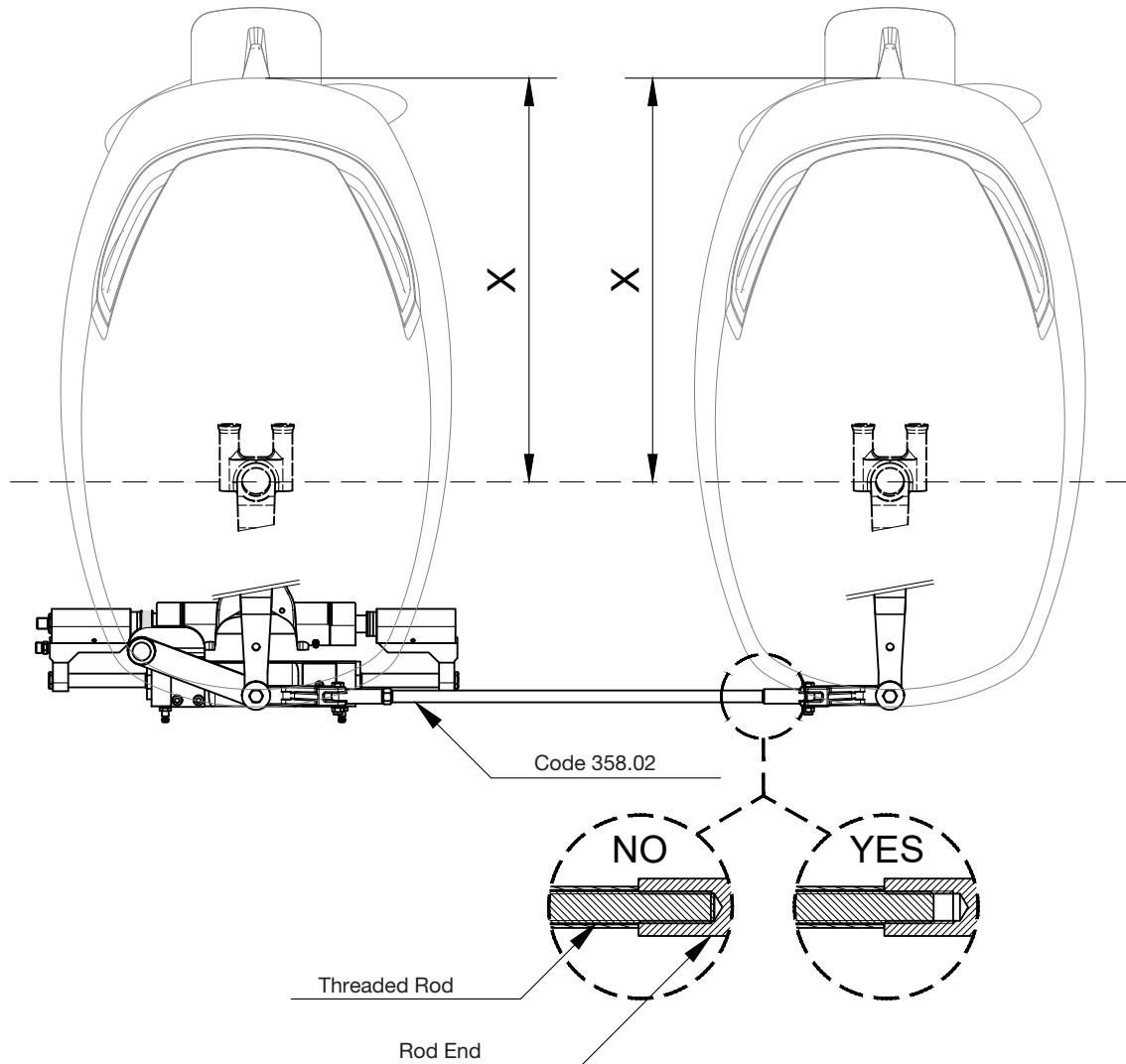

Cut the threaded bar and tube to the length calculated according to the distance of the motors.

#### WARNING

As the tiller arm position varies from engine to engine and the distance between two engines is not predictable, unexpected interferences may occur while tilting. A duly check of the tie bar installation is then strongly recommended.

#### WARNING

Do not block the threaded rod against the rod end terminal. The threaded rod should be able to rotate freely. Do not apply Loctite. Failing to observe this warning may result in damage of the tie bar while tilting one of the two engines.

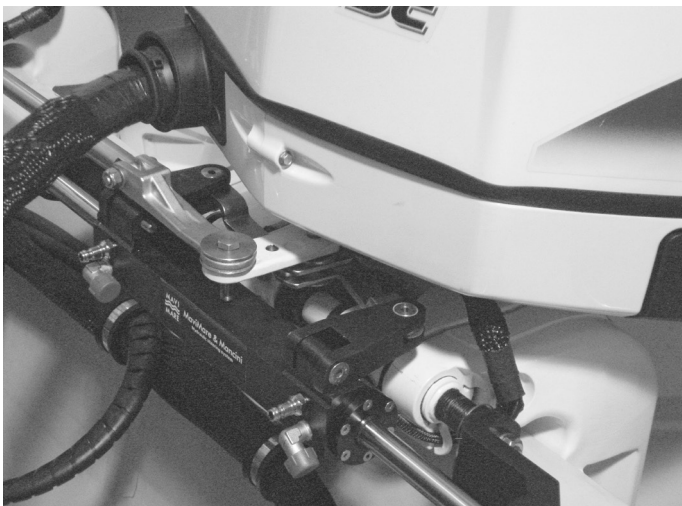

■ ■ ■ Triple engine application with two cylinder and tie bar - code 358.08 - 358.08R  
code 358.09 - 358.09R

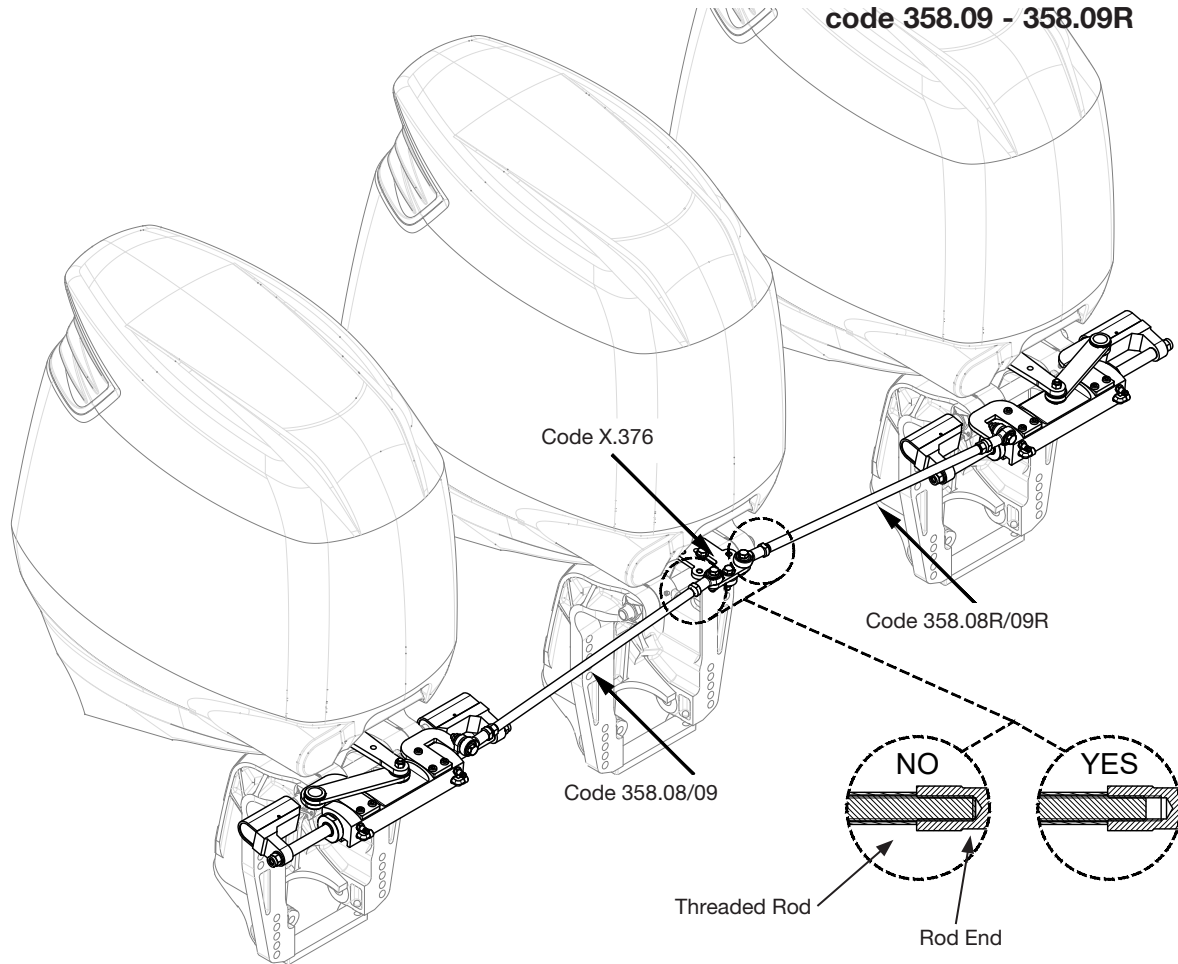

**Installation steps**

- 1 Cut the threaded bar and tube to the length calculated according to the distance of the motors.
- 2 Using a 3 mm allen wrench, remove the stainless-steel plate on the cylinder (1)
- 3 Install the stainless-steel plate of the tie bar (2) on the cylinder. Using a 5 mm open end wrench, tighten 2 screws M8x50 (3) and 1 screw M8x10 (4) with a torque of 76 Nm (56 lb ft).

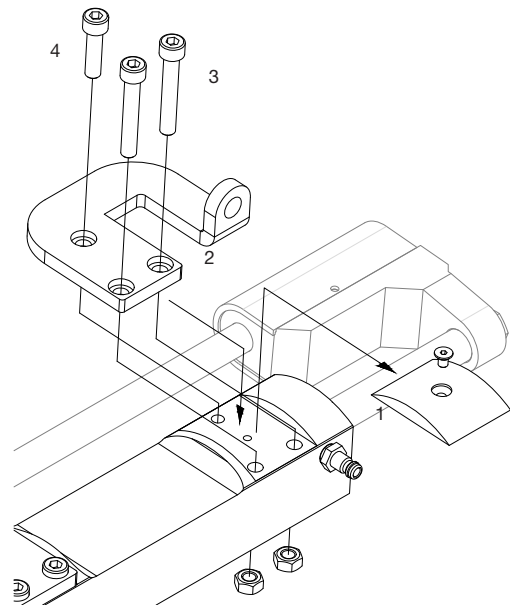

**WARNING**

As the tiller arm position varies from engine to engine and the distance between two engines is not predictable, unexpected interferences may occur while tilting. A duly check of the tie bar installation is then strongly recommended.

**WARNING**

Do not block the threaded rod against the rod end terminal. The threaded rod should be able to rotate freely. Do not apply Loctite. Failing to observe this warning may result in damage of the tie bar while tilting one of the three engines.



■ ■ ■ Twin engines application with tie bar code Code 358.07 - 358.08

Installation with single cylinder

Code 358.09 - 358.10

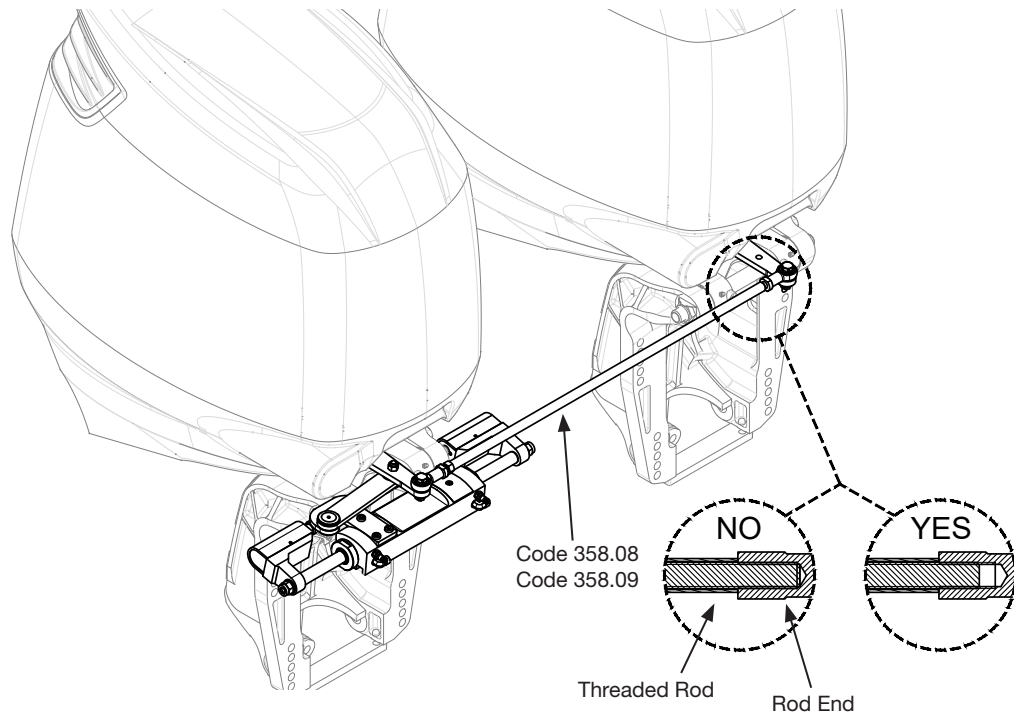

Installation with double cylinder

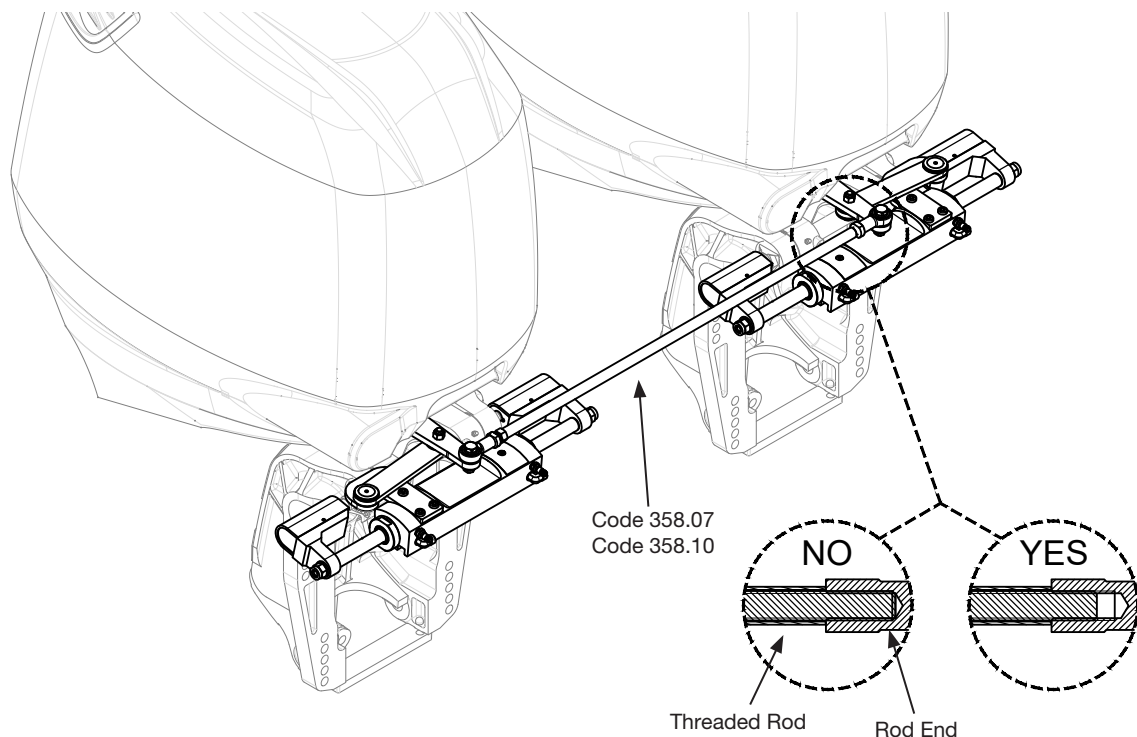

Cut the threaded bar and tube to the length calculated according to the distance of the motors.

**WARNING**

As the tiller arm position varies from engine to engine and the distance between two engines is not predictable. Unexpected interferences may occur while tilting. A duly check of the tie bar installation is then strongly recommended.

**WARNING**

Do not block the threaded rod against the rod end terminal. The threaded rod should be able to rotate freely. Do not apply Loctite. Failing to observe this warning may result in damage of the tie bar while tilting one of the two engines.

■■■ Installation instructions for ORB fitting on MC 90B / MC 150BR cylinder



- 1 Unscrew and back off lock nut (1), counterclockwise, until it stops as shown in the picture.
- 2 Screw the thread fitting into the cylinder (2) until fitting washer (3) touches the face of the cylinder (4)

**⚠ WARNING**

DON'T USE teflon tape or any type of scotch tape.

DON'T APPLY any type of sealant such as Loctite 542 or similar.

- 3 Re-position fitting (5) to desired orientation by turning it counterclockwise to a maximum of 1 full turn. After that, using a 16 mm open end wrench, tighten the fitting lock nut (6) with a torque of a 20 Nm (15 lb ft).

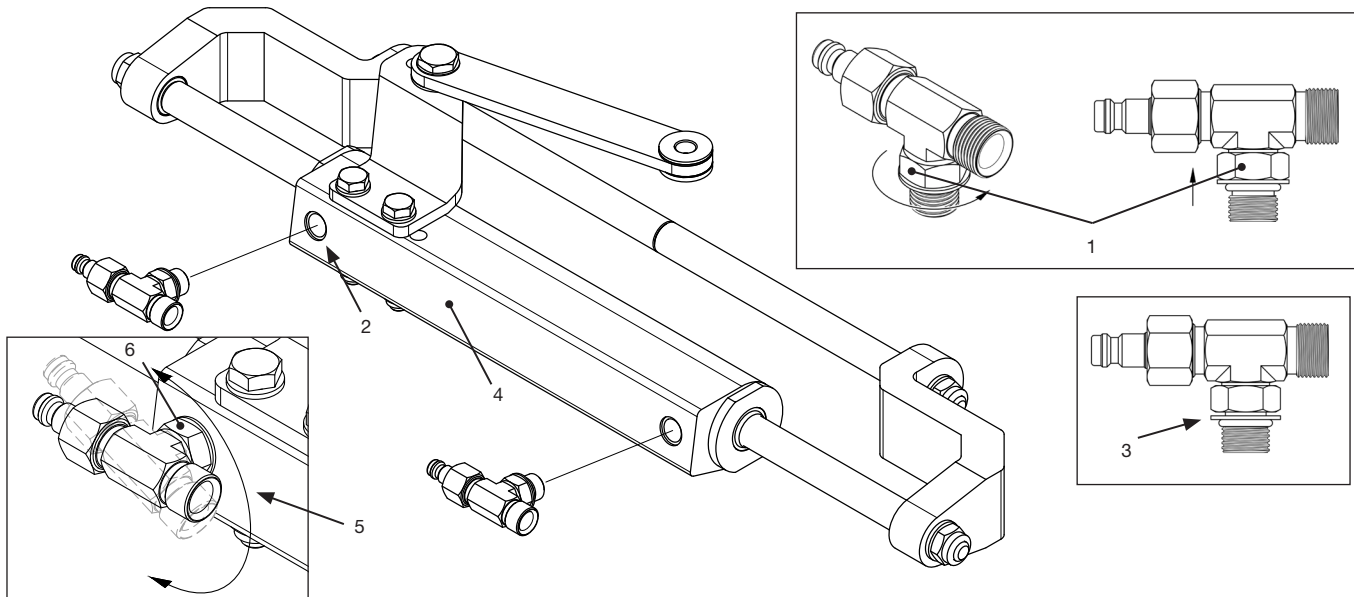

■■■ Installation instruction for ORB fitting on MC 300HD/ MC 350HD cylinder

**ⓘ NOTE**

The installation of the ORB fittings must be done before the installation of the bleeders on the cylinder. If they have already been mounted, it is necessary to remove them by unscrewing them using a 13 mm open end wrench.

- 1 Unscrew and back off lock nut (1), counterclockwise, until it stop as show in the picture.
- 2 Thread fitting into the cylinder (2) until fitting washer (3) touches the face of the cylinder (4).

**⚠ WARNING**

DON'T USE teflon tape or any type of scotch tape.

DON'T APPLY any type of sealant such as Loctite 542 or similar.

- 3 Re-position fitting (5) to desired orientation by turning it counter clockwise to a maximum of 1 full turn. After that, using a 16 mm open end wrench, tighten the fitting lock nut (6) with a torque of a 20 Nm (15 lb ft).
- 4 Using a 13 mm open end wrench, screw the bleeders (7) on the cylinder.

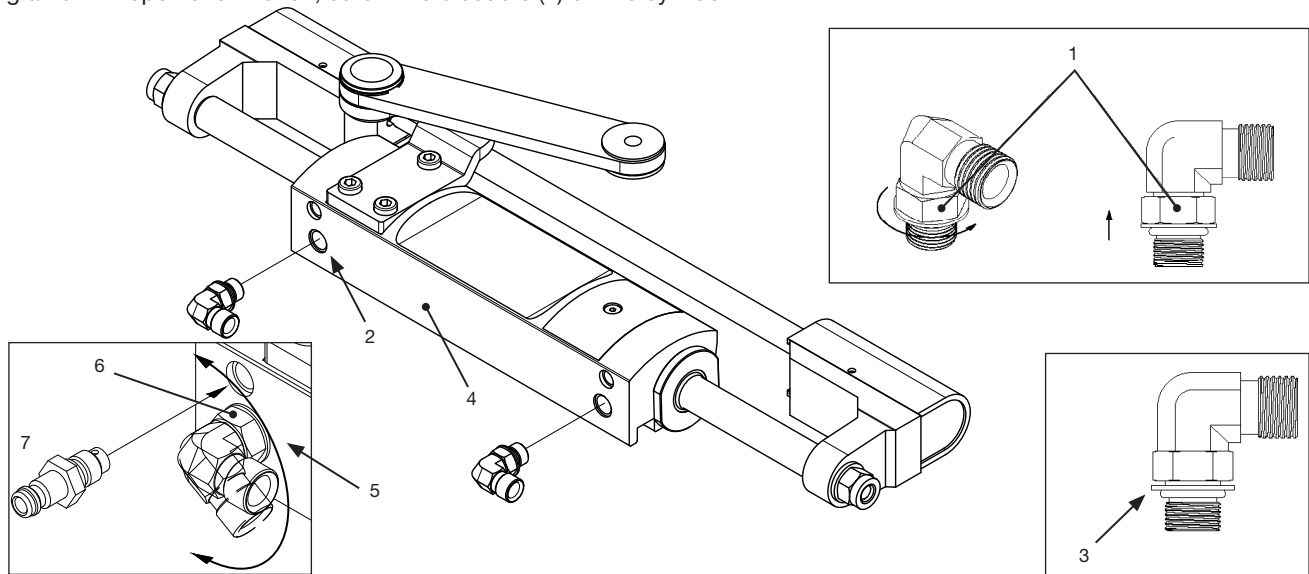

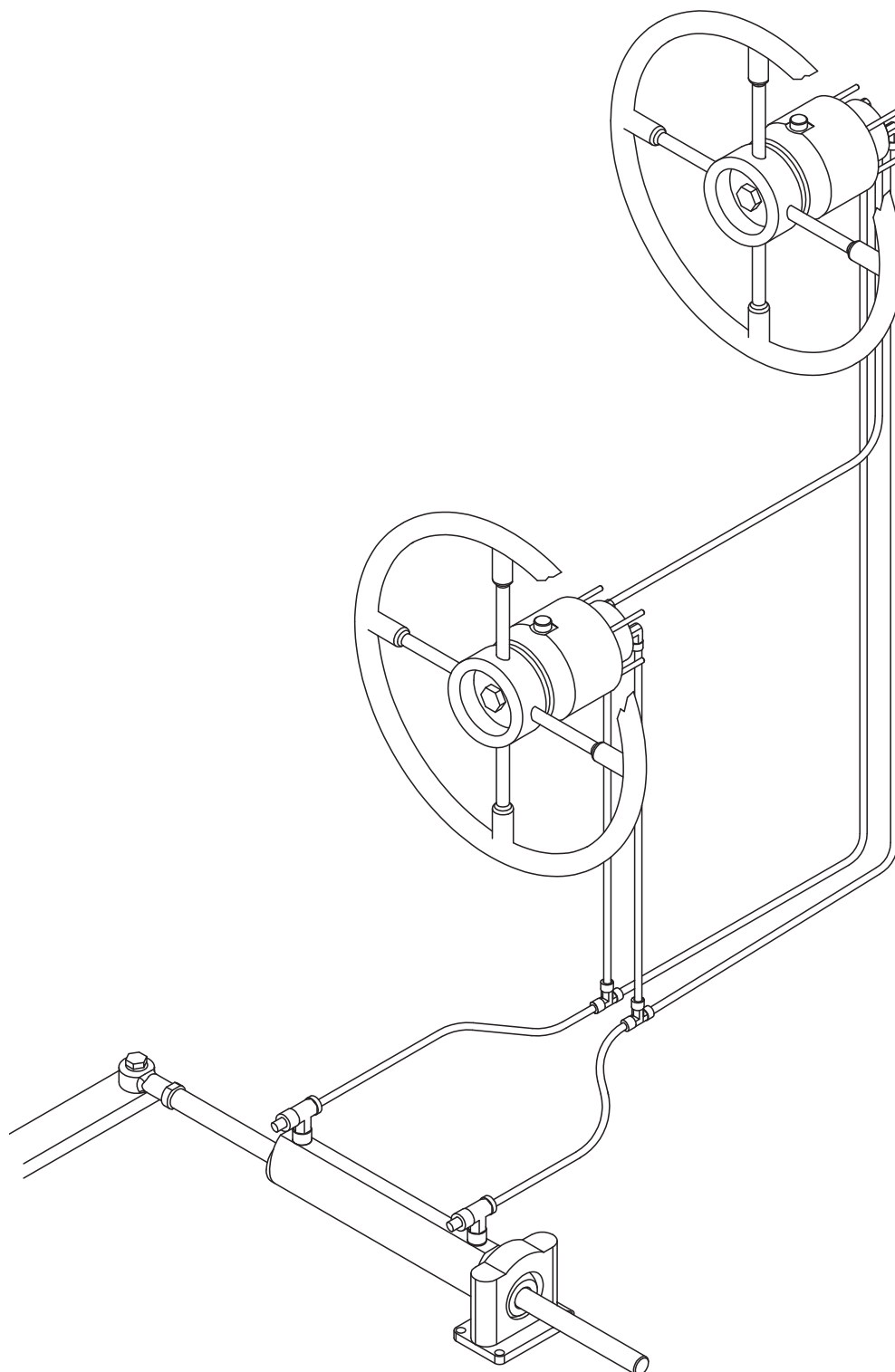
**Typical Inboard Steering System**

■■■ Installation instructions for GE30 / GE50 / GE75 / GE100 cylinder

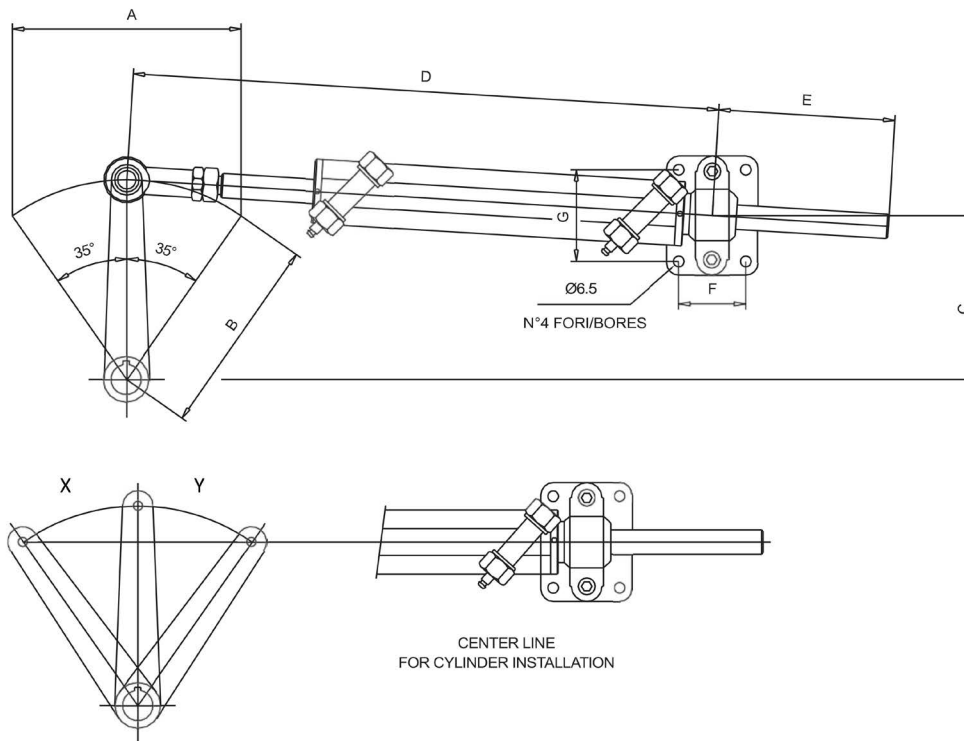

TYPE	A		B		C		D		E		F		G	
	mm	inches	mm	inches	mm	inches	mm	inches	mm	inches	mm	inches	mm	inches
CE30	150	5.9	131	5.16	107	4.2	383	15.1	96	3.8	44	1.73	60	2.36
CE50	150	5.9	131	5.16	107	4.2	405	16	96	3.8	44	1.73	60	2.36
CE75	215	8.5	187	7.36	155	6.1	510	20.9	130	5.1	44	1.73	60	2.36
CE1000	215	8.5	187	7.36	155	6.1	510	20.9	130	5.1	44	1.73	60	2.36

Proper cylinder installation is the key to the successful operation of the hydraulic steering system.

**⚠ WARNING**

An incorrectly-installed cylinder is subject to rapid seal and bearing wear and non-repairable damage.

**⚠ WARNING**

Protect cylinder shafts from nicks and scratches, which can cause cylinder to leak, and result in loss of steering.

**Installation steps**

- 1 Select your cylinder size in the table.
- 2 To achieve maximum cylinder performance it is suggested that an imaginary line is drawn through the tiller arm hole at both hard over positions. This will create the cylinder center line. With the tiller arm in hard-over position, angle X and Y should be the same.
- 3 Line up helm in bow-stern direction. Join the piston rod ball joint to the tiller helm. Loosen pipe fitting nuts.
- 4 Keeping bow-stern direction and using piston rod stroke, place the bracket complying with "D", "E" and "C" sizes, as indicated in the table.
- 5 Place the cylinder bracket complying with dimensions indicated in the table and fasten using the four 6 mm bolts (not supplied) and the four stainless-steel locknuts (not supplied). For correct installation, check the cylinder is free in each point of its stroke and aligned with transom.
- 6 Move the tiller and check that the cylinder stroke is free.
- 7 Check that ball joints are free.

When linking two tillers by tie rod, the cylinder may be mounted on the tie rod or on each tiller.

### ■ ■ ■ Table of tightening torque of inboard cylinders

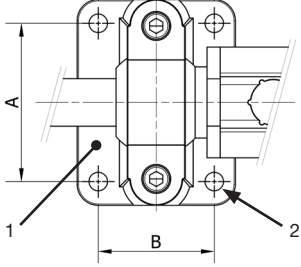
<p>Bracket fixing (1) using 4x6 mm bolts and 4 M6 nuts (2) (not included) in stainless steel of min. class A2-70 (ISO 3506-1)</p>		<p>Tightening torque  <math>F = 10 \text{ Nm}</math>  <math>F = 7.3 \text{ lb/ft}</math></p>
---	--	--

Once the cylinder is installed, it is possible to make a fine adjustment by screwing the ball joint.

 **DANGER**

The ball joint (3) must be locked by the safety lock nut (4).

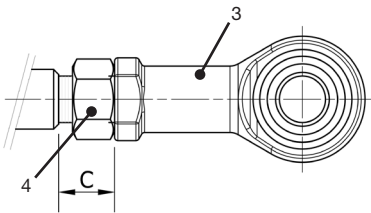

■■■ Installation instructions for MC 150E / MC 150BE / MC 300BE cylinder

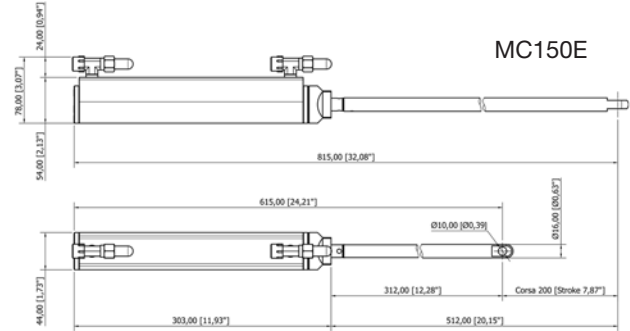
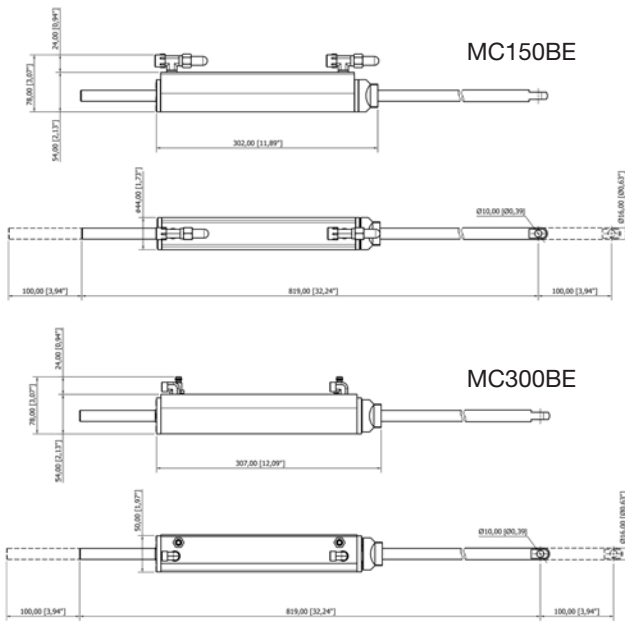

**⚠ WARNING**

It is important to check periodically, at least every 3 months (or every month for professional uses), the right torque of this bolt and of the self-locking nut.

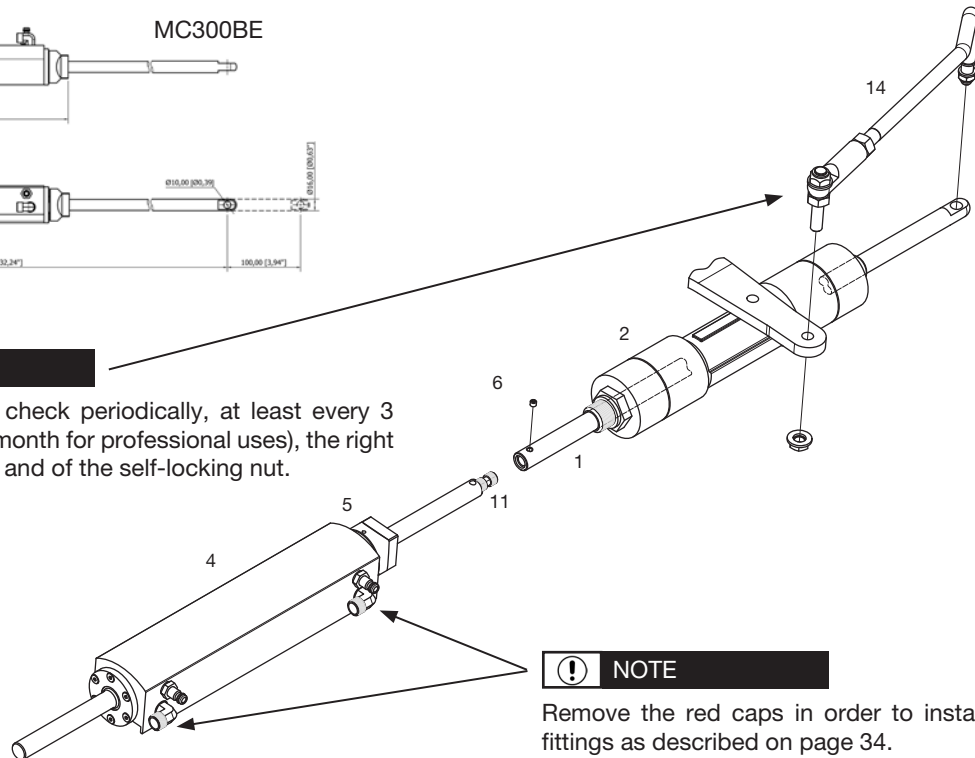

**ⓘ NOTE**

Remove the red caps in order to install the hose fittings as described on page 34.

REF.	QTY	DESCRIPTION
1	1	Extension rod
2	-	Motor tilt tube
4	1	Cylinder
5	-	Adjusting nut
6	1	Pin
14(*)	1	Tiller arm*

**ⓘ NOTE**

(\*) The tiller arm is not supplied

Proper cylinder installation is the key to the successful operation of the hydraulic steering system.

**⚠ WARNING**

An incorrectly installed cylinder is subject to rapid seal and bearing wear and non-repairable damage.

**⚠ WARNING**

Protect cylinder rods from nicks and scratches, which can cause cylinder to leak, and result in loss of steering.



## Installation steps

- 1 Ensure that the motor tilt tube is perfectly dry and clean. Grease the extension rod (1) with good-quality grease. Insert the extension rod on left side of motor tilt tube.
- 2 Using the locking hole (11) on the cylinder rod, screw the extension rod (1) onto the cylinder shaft until it reaches the end of the stroke. Using a 2.5 mm allen wrench, fix it with the pin (6).
- 3 Screw the cylinder to the left threaded side of motor tilt tube, keeping the bleeders on the upper side of the cylinder. Using a 32 mm open end wrenches, tighten the adjusting-nut (5) against the cylinder with a torque of 40 Nm (29.5 lb ft).
- 4 Connect the tiller arm (14) to the extension rod.
- 5 Put the cylinder and the motor in the middle of its stroke, and adjust the tiller arm distance. Connect the tiller arm to the motor with screw, washer and self-locking nut (15).

### WARNING

For the tightening torques during the assembly of the tiller arm, refer to the manufacturer's instructions.

### DANGER

All the systems are not intended for racing boat application.

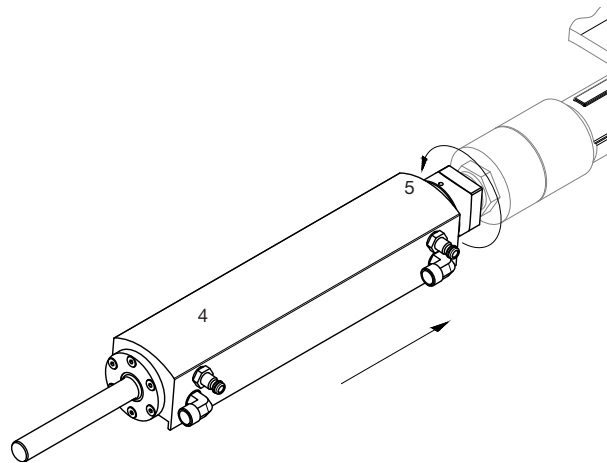

### WARNING

In case you want to remove the cylinder, rotate the nut (5) counterclockwise holding the cylinder pressed against the nut itself. Failure to observe this warning may result in the breaking of the nut itself.

## ■■■ Installation instructions for CE50S cylinder

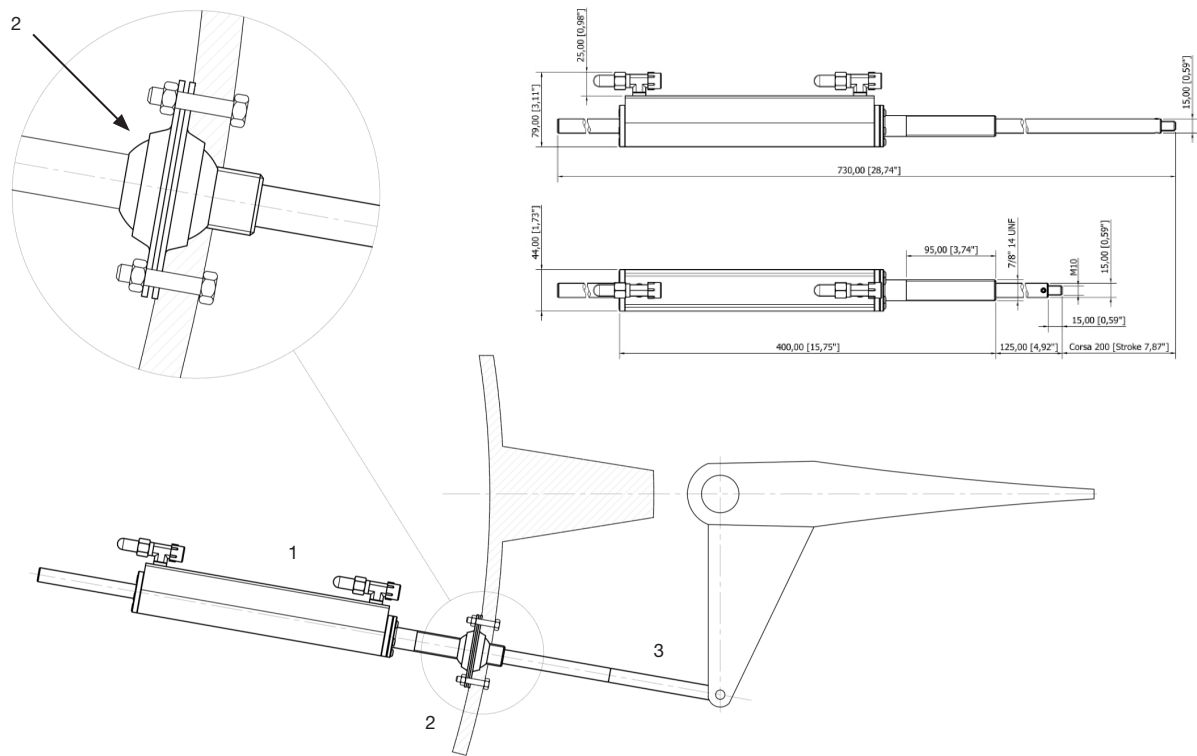

REF.	QTY	DESCRIPTION
1	1	CE50S cylinder
2(*)	-	Code A.185*
3	-	Support rod

### NOTE

(\*) Code A.185 (ball joint with adjustable flange) is not supplied.

Proper cylinder installation is the key to the successful operation of the hydraulic steering system.

### WARNING

An incorrectly installed cylinder is subject to rapid seal and bearing wear and non-repairable damage.

### WARNING

Protect cylinder rods from nicks and scratches, which can cause cylinder to leak, and result in loss of steering.

## Installation steps

- 1 Install code A.185 (2) if it's not already installed on the boat.
- 2 Screw the cylinder (1) to the ball joint with adjustable flange (2) and connect the support rod (3) to the tiller arm.

### DANGER

All the systems are not intended for racing boat application





### ■■■ SAE100R7 hydraulic hose installation

The pumps and cylinder shall be connected to each other by SAE100R 7-1/4 or SAE100R7 5/16 hydraulic hoses with reusable fittings as shown in the following table.

HOSE	FITTING
SAE100R 7-1/4	Code AC10/T916
SAE100R 7-5/16	Code AC38/T916

#### WARNING

MAVIMARE recommends using these fittings only with MAVIMARE steering hoses.

Always try to route the hoses via the shortest path in order to avoid any possible loss of power. In order to make the air bleed off the system more easily, it is suggested mounting the hoses horizontally with an inclination of about 3 cm per meter; the pump side has to be higher than the cylinder side.

Always protect the hoses which have to pass through a different compartment or use suitable bulkhead connectors or sleeve. Hoses have to be installed in such a way they don't represent an obstacle for other components.

Do not remove protective end covers until the hoses have been routed and are ready to be connected to the helm pump, hose fitting or steering cylinder/s.

Provide sufficient hose lengths to allow for cylinder movement throughout the turning arc and up/down trim/tilt settings of the engine/s. Throughout the hose installation, ensure the protective caps remain installed onto the end of the hoses.

#### WARNING

Do not install hoses in an area where they will be exposed to high heat. Extreme heat reduces the hose bursting pressure and can cause the hose melting.

#### WARNING

Check that hoses don't interfere with the transom even during the engine tilting.

#### WARNING

Make sure that the hoses bend radius is never less than 250 mm. Excessive bending may damage the hose and result in a malfunction of the hydraulic system.

In case of damage, it will be necessary to proceed with the replacement of the hose.

#### WARNING

Exercise great cleanliness. Make sure that pipes and hoses are perfectly clean and free from swarf.



### Installation steps

- 1 Shorten hoses by using cutters or nippers.

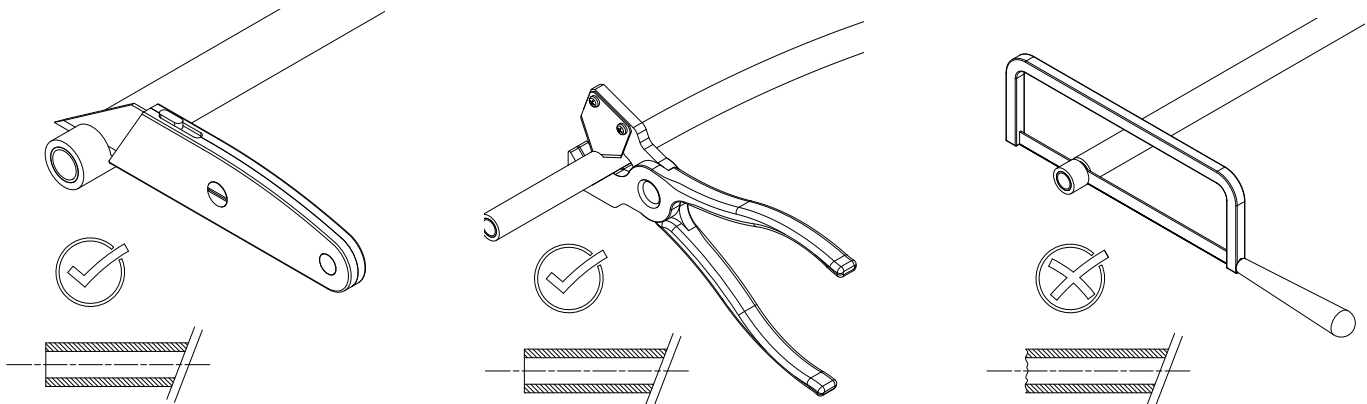

#### WARNING

In this step never use tools with toothed blades such as hacksaws or similar, as the swarf residues penetrating into the hydraulic steering system would cause it to break down making it unusable.

- 2 After cutting, lubricate slightly the external part of the hose (1) where you want install the fitting.

 **WARNING**

Pay attention that the grease does not enter into the hose.

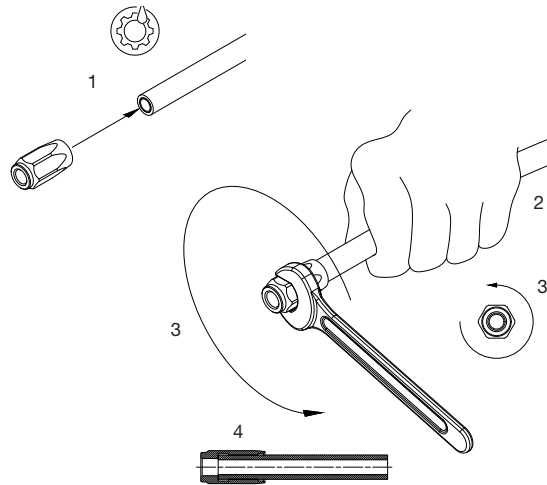

- 3 Holding the hose (2) in place, using a 17 mm (Code AC10/T916) or 19 mm (Code AC38/T916) open end wrench, screw the tube coupling sleeve (3) in a counterclockwise direction onto the end of the hose (left-hand thread).

 **WARNING**

Be very careful not to damage the pipe.

 **DANGER**

When finished, make sure that the fitting is fully screwed (4). If the connection is only partially screwed, the hydraulic steering system may malfunction and lose control of the vessel, causing damage to persons or property.

 **DANGER**

In this step don't use power tools that could damage the hose.

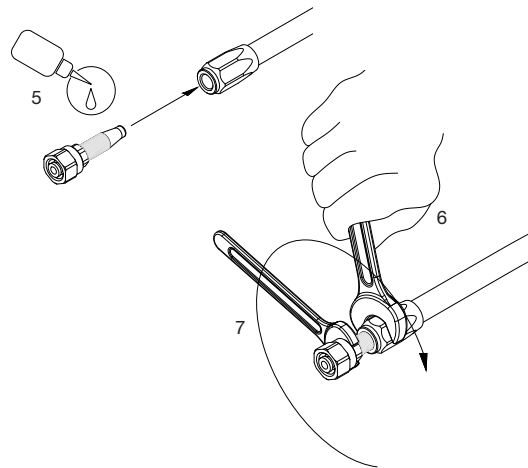

- 4 Oil the hose coupling (5). Using a 17 mm (Code AC10/T916) or 19 mm (Code AC38/T916) open end wrench, hold the tube coupling sleeve (6) firmly and with a 14 mm open end wrench screw the hose coupling into the sleeve.

 **WARNING**

Make sure that the internal sheathing of the tubing does not follow while tightening the screw! Also make sure that the internal sheathing of the tubing is not squeezed while tightening the screw.

- 5 Check there is no internal interference putting a small screwdriver into the tube coupling before proceeding with hose installation to helm or cylinder.**

### ■■■ Hose connection (single cylinder)

Refer to the illustrations below for correctly connecting hoses from helm pump to cylinder.

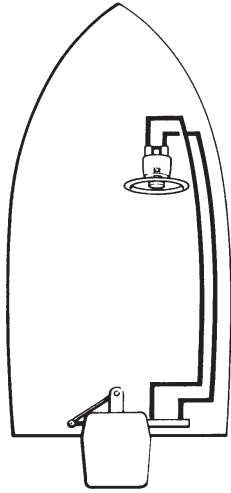

for MC150 / MC150E / MC150BE / MC150R / MC300R  
for CE30 / 50 / 75 / 100

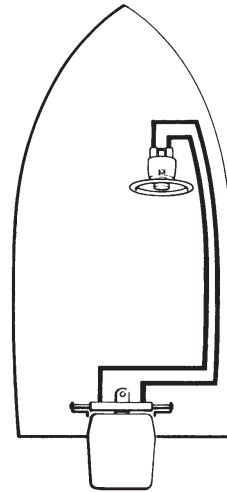

for MC300HD - MC350HD  
for MC150BR - MC90B

### ■■■ Hose connection (double cylinder)

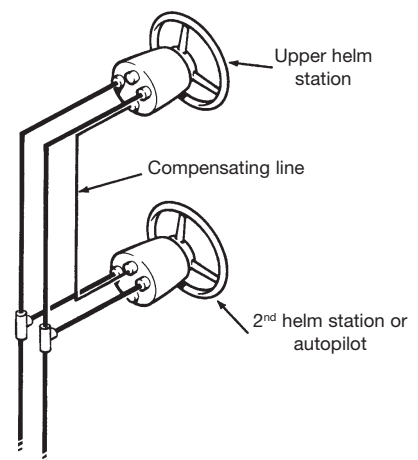
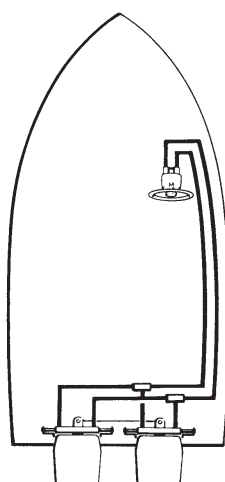
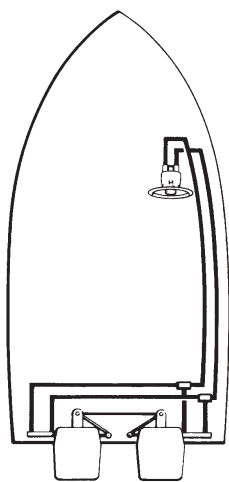

■■■ Connection scheme for double hydraulic cylinder code X.351

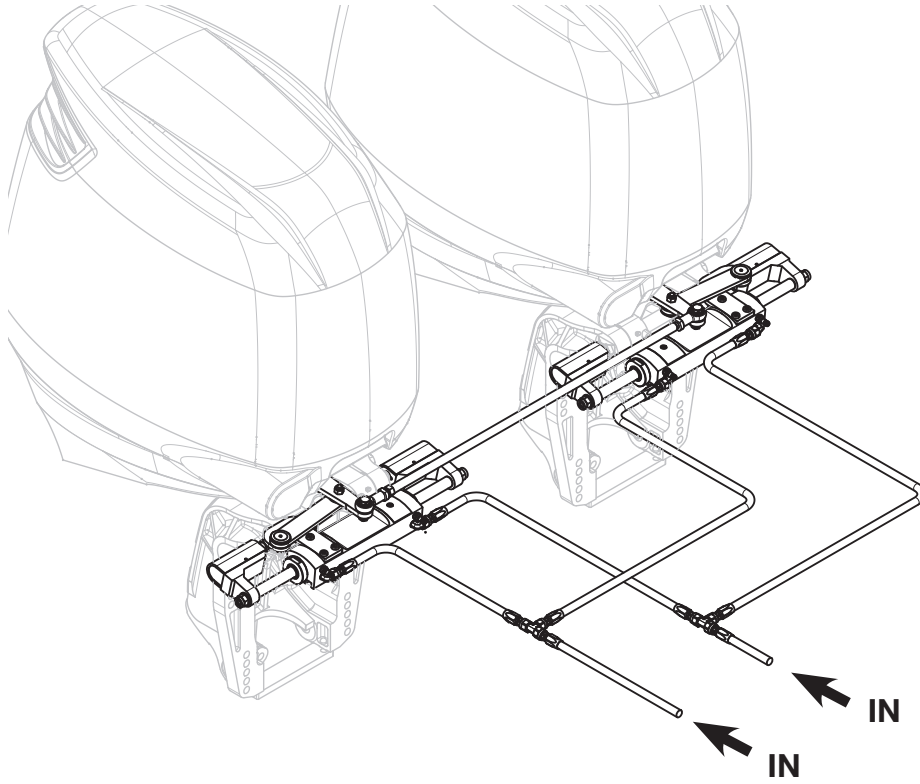

■■■ Connection scheme for double hydraulic cylinder code X.352

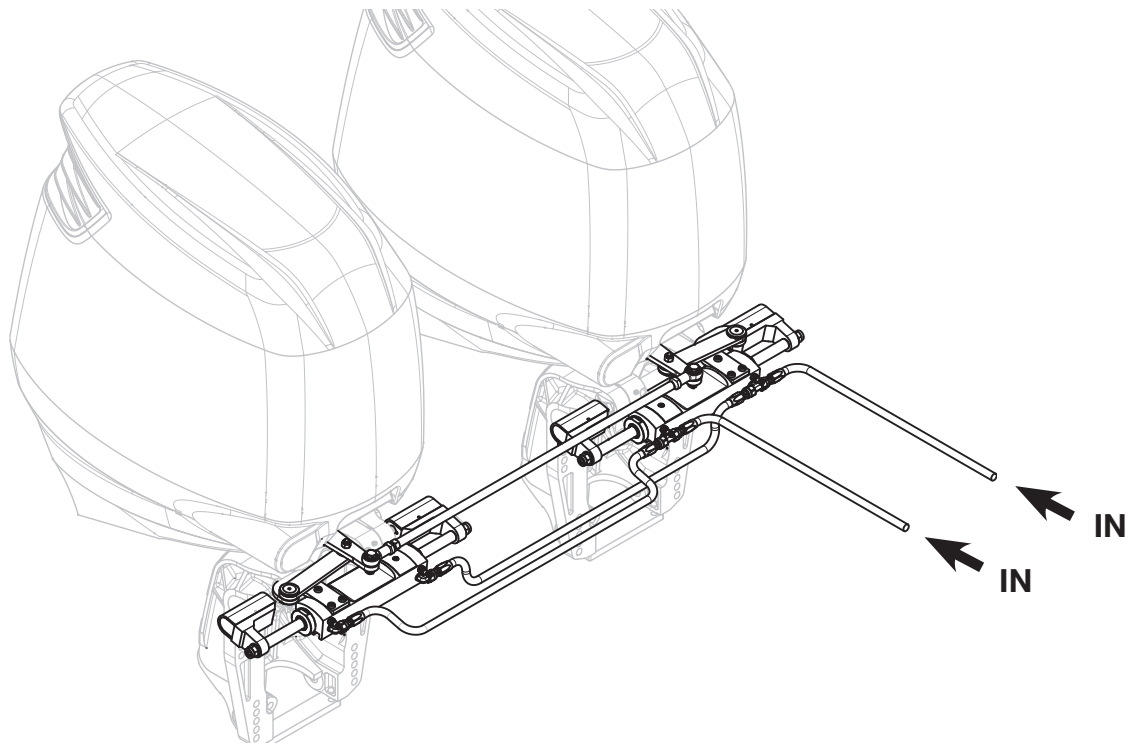

### ■■■ Hydraulic Fluid

Recommended oils for your steering system are:

#### MAVIMARE HYDRALUIC FLUID SHELL TELLUS T15 (CL T15 HIV)

Viscosity	15 cst
Viscosity index	142
Solidification point	c° -38

Note: Automation transmission fluid Dexron II may be used in case of emergency.

Never use brake fluid. Any non-approved fluid may cause irreparable damage, loss of steering, and loss of warranty coverage.

### ■■■ Filling and purging the outboard systems (single station)

This Procedure requires the presence of two people. A single person may not be able to remove all the air from the system which will result in spongy, unresponsive steering.

During the entire filling procedure, oil must be visible in the filler tube. Do not allow the oil level to disappear into the helm pump as this may introduce air into the system and increase your filling time.

#### Step no.1

Connect the threaded end of the filler tube to the oil bottle and screw it into the helm filler port. Poke hole in the bottom of the bottle. Fill the helm pump full of hydraulic oil so that it is visible in the filler tube.

Do not proceed with step two until helm is full of oil.

#### Step no.2

Turn the steering wheel clockwise until the cylinder rod is fully extended on the right side of the cylinder.

Open right side bleeder.

#### Step no.3

Holding the cylinder body (Front Mount Cylinder) or rod (Lateral Mount Cylinder) to prevent the body/ rod from moving, turn the steering wheel counter-clockwise until a steady stream of air-free oil comes out of the bleeder. Do not use anything other than your hands to restrain the cylinder body/rod.

While continuing to turn the wheel close the right side bleeder and let go of the cylinder body/rod.

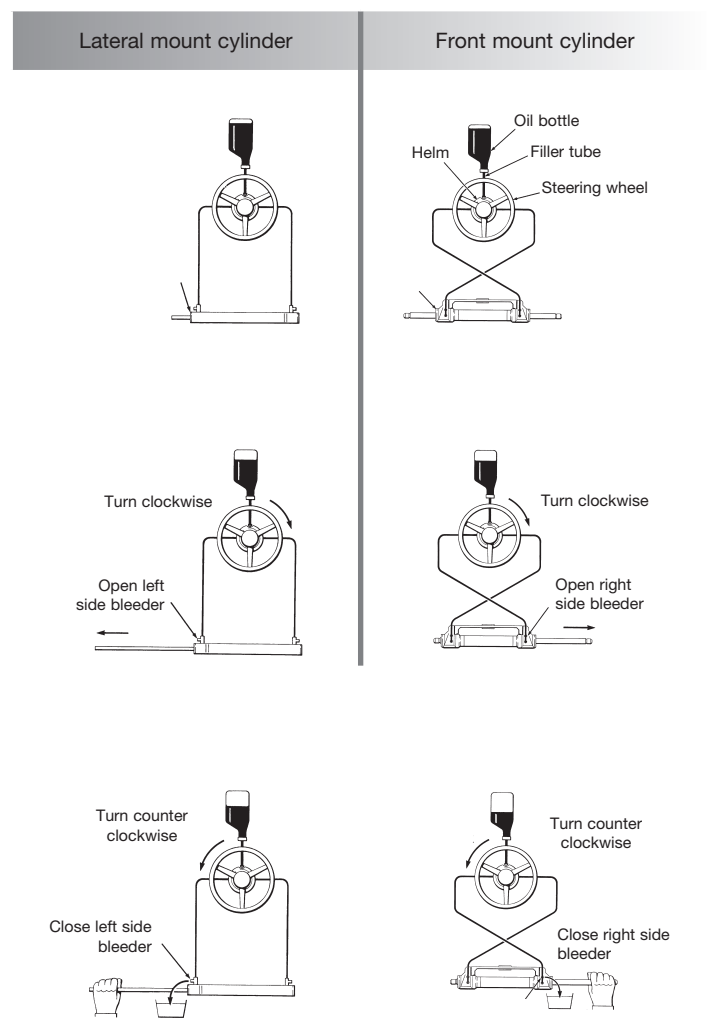

**Step no.4**

Continue turning the steering wheel counter-clockwise until the cylinder rod is fully extended to the left (Steering wheel will come to stop).

Open the left bleeder and perform the same operation as in step 3 (turning the wheel clockwise).

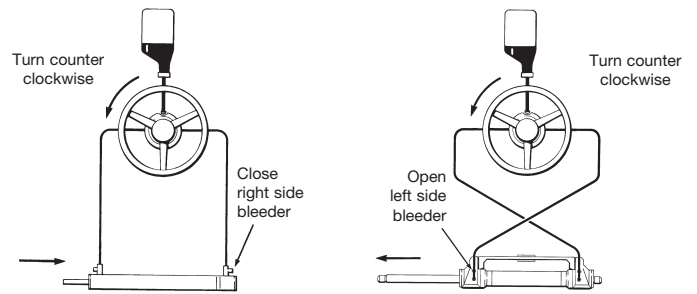

**Step no.5**

Holding the cylinder body (Front Mount cylinder) or rod (Lateral Mount cylinder) to prevent the body/rod from moving, turn the steering wheel clockwise until a steady stream of air-free oil comes out of the bleeder.

While continuing to turn the wheel, close the left side bleeder and let go of the cylinder body/rod.

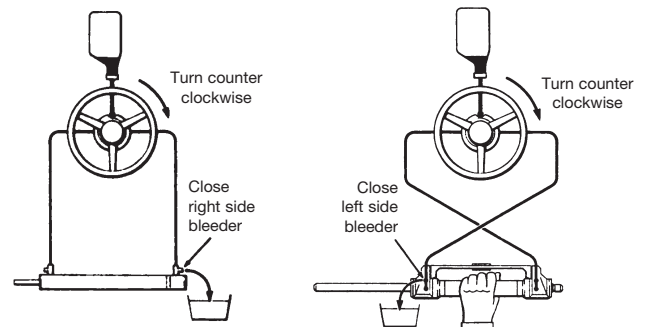

**Attention:**

Lateral mount cylinders are unbalanced. The oil level in the helm must be set with the cylinder rod fully retracted. Failing to observe this caution will result in an oil spill from the helm. Turning the wheel to port (left) will make the cylinder rod retract.

Now check the steering system. Turn the wheel (any one multi-steering station) and pressurise very hard to port. Apply enough force to the wheel to exceed pressure relief valve pressure. While pressure is maintained on steering wheel, check all port (left) fittings and line connections for leaks.

## ■■■ Filling and bleeding the systems

### TWIN STATION - SINGLE CYLINDER

Perform steps 1 through 5 for station no.1.  
Then repeat steps 1-5 for station no.2.  
Oil requirement: 4-5 bottles.

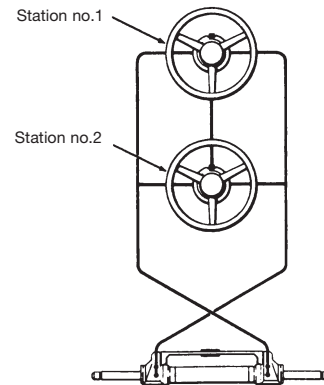

### SINGLE STATION - TWIN CYLINDER

When performing steps 1 through 5, perform instructions in each step first on cylinder no.1 and then on cylinder no.2, before proceeding to the next step, i.e.: Perform instructions referring to right side of cylinder first on cylinder no.1 and then on cylinder no.2. Oil requirement: 4-5 bottles.

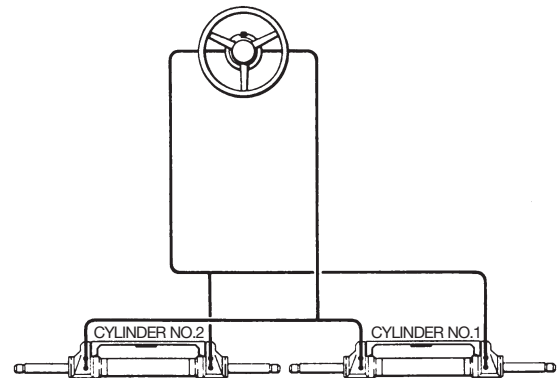

### TWIN STATION - TWIN CYLINDER

Follow the same procedure as the one for single-station/twin cylinder, beginning from station no.1 and repeat entire procedure for station no.2.

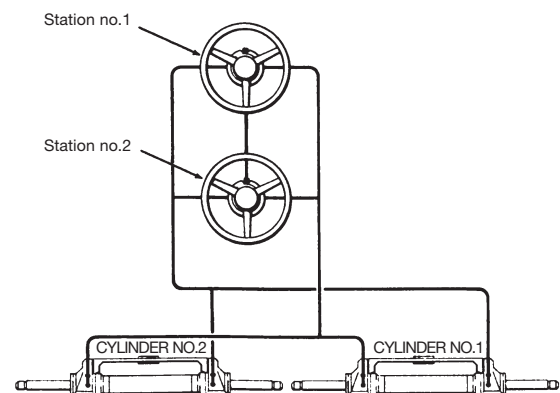

### ■■■ Filling and purging inboard/sterndrive balanced type single station one cylinder

This Procedure requires the presence of two people. A single person may not be able to remove all the air from the system which will result in spongy, unresponsive steering.

During the entire filling procedure, oil must be visible in the filler tube. Do not allow the oil level to disappear into the helm pump as this may introduce air into the system and increase your filling time.

#### Step no.1

Screw the threaded end of the filler tube into the helm filler hole. Remove the cap from the oil bottle and holding it upright, screw it into the filler tube bottle cap. Poke a hole in the bottom of the bottle. Fill the helm pump full of oil (oil should always be visible in the filler tube). Use the next bottle at any time throughout the procedure when the oil level drops in the filler tube. Do not proceed with step two until helm is full of oil.

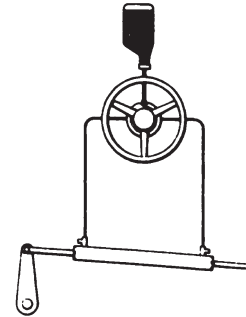

#### Step no.2

Turn the steering wheel clockwise until the cylinder rod is fully extended on the left side of the cylinder. Open left side bleeder.

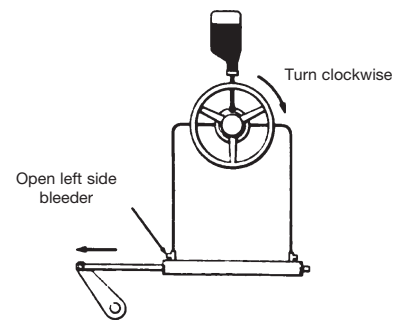

#### Step no.3

Holding the cylinder rod (to prevent it from moving back into the cylinder) turn the steering wheel counter-clockwise until a steady stream of air-free oil comes out of the bleeder. (Drain out approx. 1/2 bottle of oil or as required.)

While continuing to turn the wheel, close the left side bleeder and let go of the cylinder rod.

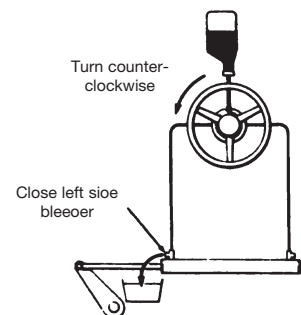

#### Step no.4

Continue turning the steering wheel counter-clockwise until the cylinder rod is fully extended to the right. (Steering wheel will come to a stop)

Open the right bleeder.

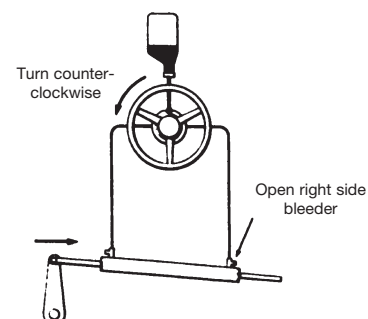



**Step no.5**

Holding the cylinder rod (to prevent it from moving back into the cylinder) turn the steering wheel clockwise until a steady stream of air- free oil comes out of bleeder.

While continuing to turn the wheel, close the right side bleeder and let go of the cylinder rod.

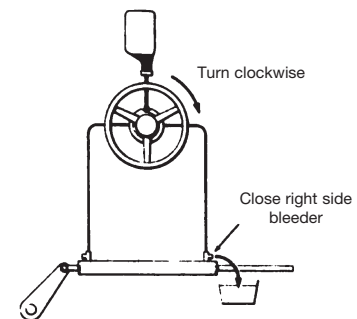
**■■■ Filling and bleeding the inboard systems****TWIN STATION - SINGLE CYLINDER**

Perform steps 1 through 5 for station no.1.  
Then repeat steps 1-5 for station no.2.  
Oil requirement: 4-5 bottles.

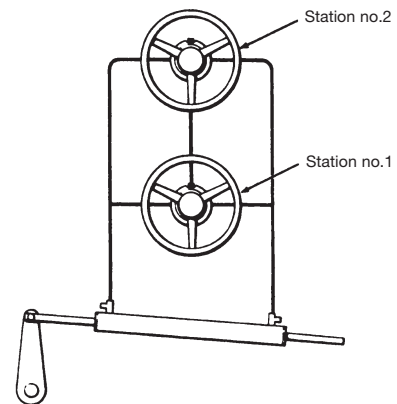
**SINGLE STATION - TWIN CYLINDER**

When performing steps 1 through 5, perform instructions in each step first on cylinder no.1 and then on the cylinder no.2, before proceeding to the next step. i.e.: perform instructions referring to right side of cylinder first on cylinder no.1 and then on cylinder no.2.

Oil requirement: 4-5 bottles.

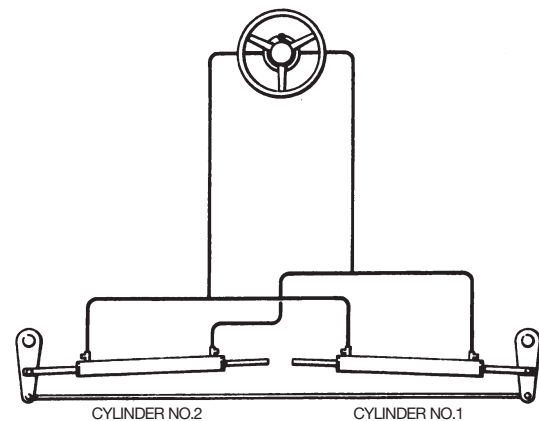
**TWIN STATION - TWIN CYLINDER**

Follow the same procedure as the one for single-station/twin cylinder, beginning from station no.1 and repeat entire procedure for station no.2.

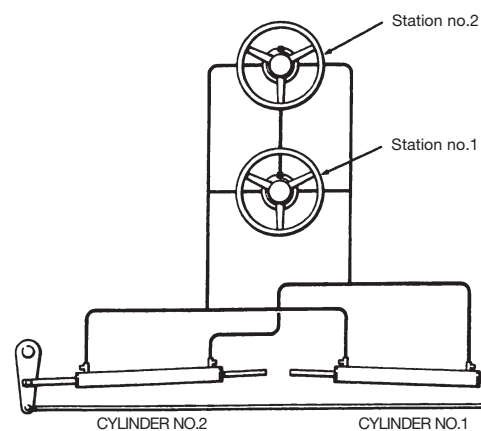

### ■■■ Valves installation

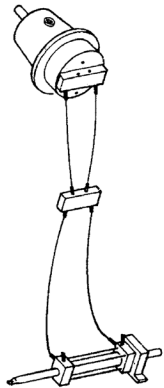

**MR4 LOCK VALVE:**  
In-line mounting. It keeps the rudder stopped in its position, avoiding any shock caused by heavy sea.

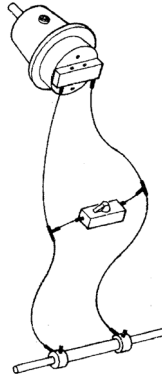

**MBY4 BYPASS VALVE:**  
In-line mounting. It allows the short-circuit of the system to execute the manual control in an emergency.

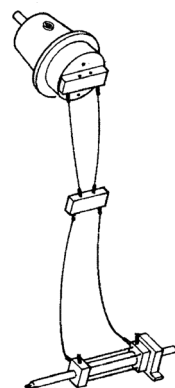

**MM4 SAFETY VALVE:**  
In-line mounting. It avoids the overpressures.

### ■■■ Dual station installation schemes

The system has been designed to avoid maintenance. Anyway, if the hydraulic steering system is not used for a long time, it is better, before reactivating it, to turn the wheel until the stroke-end, first on one side and then on the other

- grease the exterior of the inboard cylinder abundantly
- vaporize a lubricant on the outboard cylinder regularly.

**Warning:**

- we advise to use oil "SHELL TELLUS T15"
- make sure the oil is perfectly clean and that no impurities have entered in the system
- avoid strong shocks to the pump and to the cylinder (collision, hammer-blows, etc.)

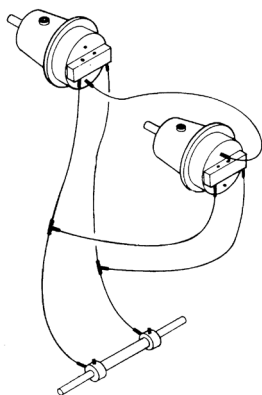

Outboard double station scheme

In double stations, the lower helm fill-vent plug must be replaced with a non-vent plug, which is included in a dual station fitting kit

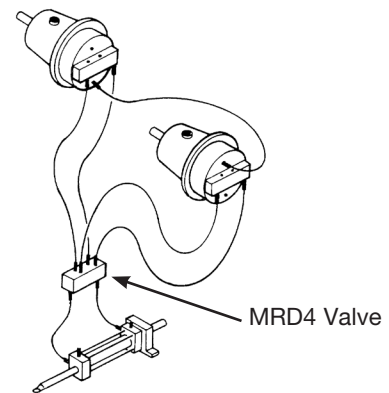

Inboard double station scheme with MRD4 valve

### ■■■ Catamaran outboard systems

In applications where a mechanical tie bar cannot be fitted, it is recommended that you use a "Liquid Tie Bar Valve" (MBY4). This valve will serve two purposes:

- assisting with the air removal from the system;
- allowing the user to re-align the engines when misaligned.

Due to the potential leakage across the piston seals, it is possible for the engines to get out of synchronization. We are unable to predict, due to circumstances beyond our control, the frequency when misalignment may occur, therefore engine alignment should be checked and corrected as required before leaving the dock.

Due to plumbing requirements, "Liquid Tie Bar" systems should use 27cc helm pump (GM2-MRA01). Even though there are physically two cylinders in the system, the total volume of the system is that of one cylinder. Use of a 32cc (like GM2-MRA03) helm will result in heavier steering effort.

Bleeding of a "Liquid Tiebar System" is different than a system fitted with a mechanical tiebar. Please refer to your installation and manual.

Bleeding system instruction:

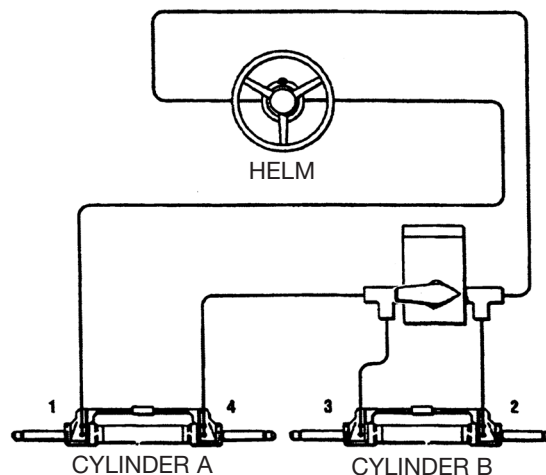

Fill helm with oil and attach filler device/container to helm.

OPEN valve.

OPEN bleed fitting 1 and pull cylinder shaft all the way out on fitting 1 side of cylinder.

Turn steering wheel clockwise until an air free stream of oil comes forth from bleed fitting 1.

CLOSE bleeder 1.

OPEN bleed fitting 2 and pull cylinder shaft all the way out on fitting 2 side of cylinder.

Turn steering wheel counter-clockwise until an air free stream of oil comes forth from bleed fitting 2.

CLOSE bleed fitting 2.

OPEN bleed fitting 3 and pull cylinder shaft all the way out on fitting 3 side of cylinder.

Turn steering wheel counter-clockwise until an air free stream of oil exits bleeder fitting 3.

CLOSE bleeder 3.

OPEN bleed fitting 4 and pull cylinder shaft all the way out on fitting 4 side of cylinder.

Turn steering wheel counter-clockwise until an air free stream of oil exits bleeder fitting 4.

CLOSE bleeder 4.

CLOSE alignment valve.

Realignment Instructions

Engines toed outwards (props too far apart).

Turn the wheel hard over to starboard: both cylinders will move - cylinder B reaching hard over first.  
Open the valve.  
Continue to turn the wheel hard over to starboard: only cylinder A will move, reaching hard over.  
Close the valve.

BALANCED CYLINDERS

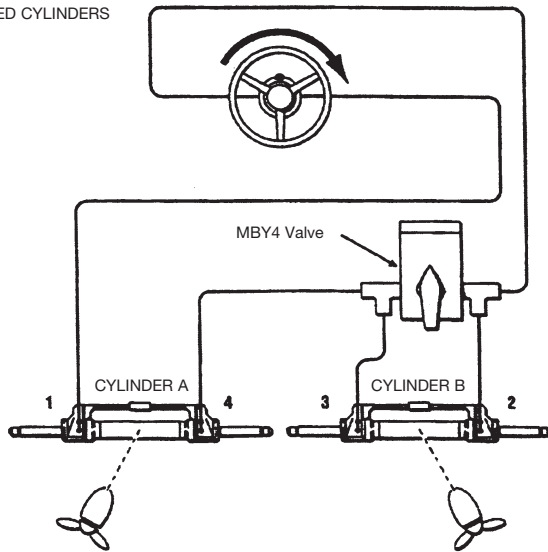

UNBALANCED CYLINDERS

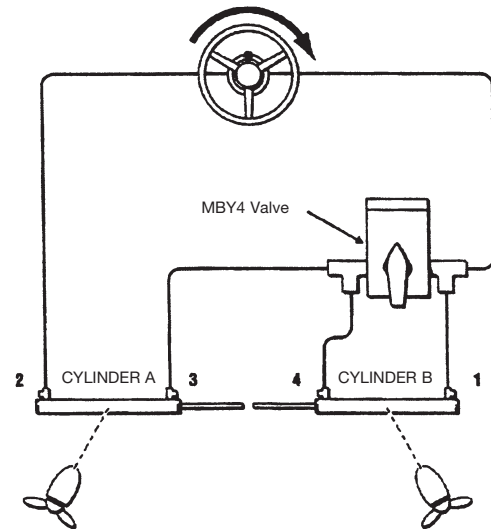

Engines toed inwards (props too close together).

Turn the wheel hard over to port: both cylinders will move - cylinder B reaching hard over first.  
Open the valve.  
Continue to turn the wheel hard over to port: only cylinder A will move, reaching hard over.  
Close the valve.

BALANCED CYLINDERS

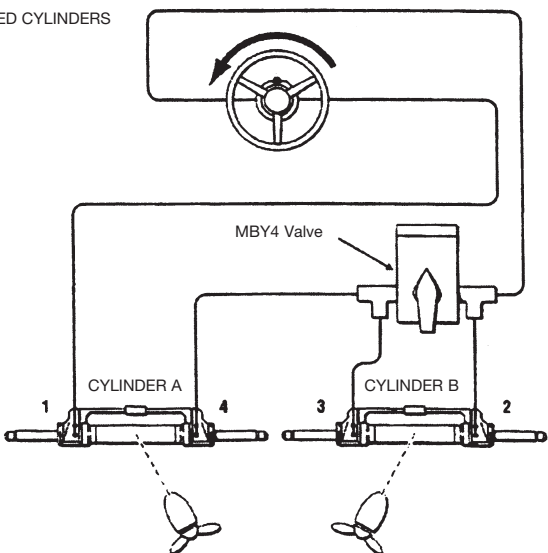

UNBALANCED CYLINDERS

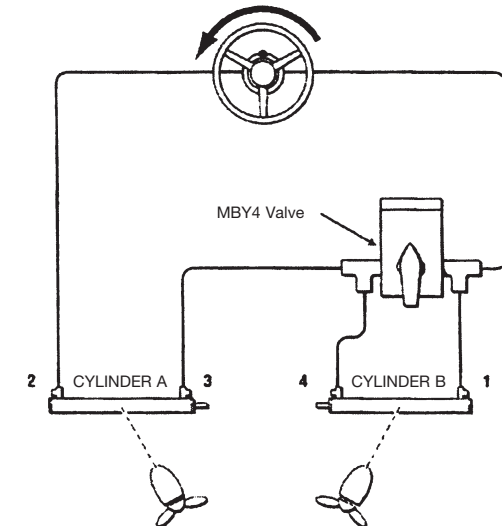

## ■■■ Troubleshooting guide

### **LUMPY OR NOTCHY STEERING**

The most common case of this complaint is air in the system. Check all fittings and re-bleed the system. It is important to note that a fitting which leaks oil can still leak air into the system. Any fittings should be very carefully inspected.

Another cause is the use of the wrong type of tubing. High-pressure flexible hoses can allow expansion, and the result is notchy steering. Be very careful – not all black nylon tubing is rated 2500 psi. The most common 1000 psi tubing looks similar but it is NOT THE SAME! Using it is dangerous – take it off the boat IMMEDIATELY, and get the right tubing.

### **OIL OVERFLOWING**

Do not overfill the pump unit, but leave the oil level about 2,5 cm from the top of the pump (about 1,2 cm from the bottom of the thread). If it still overflows on a hot day, then you have a pocket of air present in the system. Re-bleed the system.

### **TIGHT STEERING**

Once again, the most common causes are air in the system and the wrong type of tubing used. Both faults allow compression of either the air or the tubing and the storage of pressure. This stored pressure results in heavy steering. Correct either of these faults. Another cause of stiff steering is mechanical. To eliminate the problem, disconnect the steering from the tiller arm. If the hydraulic steering is now light to operate with the wheel, then you will find the rudders / engines very heavy to move with your hands. This might be the problem. Even large rudders/heavy engines should be able to move freely on their bearings. Correct the mechanical fault with the rudder gear arm engine and the steering will then deliver the designed performance.

Check the self-locking nuts and adjusting nut of the cylinder: They must not be overtightened.

The final cause of stiff steering can be the entry of foreign material in the lock-valve assembly which can jam the piston. Failure of the piston to move freely can cause a hydraulic lock effect. Cleaning the valve is not difficult but requires that the unit be returned to the factory to be cleaned and tested, whilst under warranty.

### **STEERING SLIPPING**

Should the pump appear to be slipping easily or turning without moving the cylinder, then the problem is probably related to some dirt or foreign body lodged in one of the pick-up valves inside the pump. It may affect one or, if very dirty, can affect both directions of the pump.

The simplest step to take is to try bleeding again with good clean oil. Often the object will be dislodged with rapid purge of clean oil. If this does not fix the problem, then the pump should be returned to a qualified service centre to be checked by someone familiar with our equipment. This fault most often occurs when first installing and bleeding the unit, or after carrying out some other service work requiring re-bleeding of the system.

The entry of such foreign materials is not covered by warranty, and good cleanliness would have avoided the problem.

### ■■■ Faults and solutions

Below are the most common faults and their likely cause and solution.

Sometimes when returning the wheel from a hard over position, a slight resistance may be felt and a clicking sound heard. This should not be mistaken as a fault as is it a normal situation caused by the release of the lockspool.

FAULT	CAUSE	SOLUTION
During filling the helm becomes completely jammed.	Lockage in the line between the helm(s) and the cylinder(s).	Make certain that hoses are not collapsed during installation. In this case replace hoses. The damaged hose must be replaced. Otherwise it may cause loss of steering and severe personal injury or property damage.
System is very difficult to fill.	Air in system.	Review filling instruction. Excess of oil in the pump.
Air keeps burping out of helm even after system appears full	Bleed fitting leaking.	Tighten bleed fitting.
Steering is stiff and hard to turn, even when the vessel is not moving.	Adjusting nut on over-tightened tilt tube.	To test disconnect cylinder(s) from the tiller arm and turn the steering wheel. If it turns easily, correct above-mentioned problems. Please note that excessively loose connections to tiller arm or tie bar can also cause mechanical binding.
	Restriction in hose tubing or fittings.	Note: a kinked hose will cause stiff steering and should be replaced.
	Wrong oil has been used.	Check the right oil passage. Drain the filling and bleeding system
Steering is easy to turn at the dock, but becomes hard to turn when vessel is underway	Steering wheel is too small.	Fit larger wheel if possible, see installation instructions.
	Incorrect setting of trim tab(s) engine.	Adjust tab(s)
	Air in oil.	Check the oil level and repeat the bleeding procedure as explained in this manual.
When the steering wheel is slowly turned, the rod (movable rod cylinders) or the body (fixed cylinder rod) of the cylinder do not move	Air in the system.	Repeat the filling and bleeding procedure of the system.
	Impurities into the valve.	Contact Mavimare assistance Service.

A small amount of hydraulic drift when helm pump reaches its stop point (cylinder is full stroke out) is normal. The helm pumps are not 100% locking.

## ■■■ Maintenance

### Warning:

Following the routine maintenance schedules as outlined below, in the time frame noted will ensure years of service from your Mavimare Steering System, as well as keep you and your passengers safe from the dangers that are present on and off water.

Failure to comply with maintenance checks may result in loss of steering, causing property damage and/or personal injury. Inspections are necessary every year and must be carried out by specialized marine mechanics.

Check the shaft and the o-rings of the cylinder, the o-rings of the helm pump, the fittings of the cylinder and helm pump in order to prevent leaks.

Check tightness of all fasteners/ fittings throughout the steering system.

Clean the system using fresh water and non – abrasive liquid.

Cleaning fluids containing ammonia, acids or any other corrosive ingredients must not be used for cleaning any parts of the hydraulic steering system.

Do not use brake oils or automatic transmission fluid (ATF).

Use only compatible hydraulic oils.

### Prior to every use:

- Check Fluid level in highest helm pump
- Verify immediate steering response when turning steering wheel(s)  
(Ensure engine turns when steering wheel is turned).
- Visually inspect all steering hoses and fittings for wear, kinking and/or leaks.
- Check for binding, loose, worn or leaking steering components.

Warning: DO NOT operate boat if any component is not in proper working condition.

In this case please send a picture showing the installation to [service@mavimare.com](mailto:service@mavimare.com)

Maintenance check to be done after first 20 hours - then every 100 hours or 6 months (whichever comes first):

- All points noted above
- Check tightness of ALL fasteners/fittings throughout the steering system. Tighten to correct torque specifications are required.
- Check for mechanical play or slop throughout steering system, correct as required.
- Check for signs of corrosion. If corrosion is present contact your dealer.

Maintenance check to be done after every 200 hours or 12 months (whichever comes first):

- All points noted above.
- Remove support rod from engine steering/tilt tube. Clean engine steering/tilt tube and re-grease using a good quality marine grease.
- Grease support rod liberally
- Grease all contact points shown in the cylinder and tiebar installations.  
DO NOT remove tiller bolt to re-grease.
- Remove steering wheel and re-grease wheel shaft using a good quality marine grease.
- Inspect hydraulic oil for cleanliness, flush if required.

Any work being performed on the steering system MUST be completed by a qualified mechanic with the working knowledge of the system.

## ■■■ Technical information

TYPE	GE30	GE50	GE75	GE100	GF150	GF150E	GF150R	GF150BR	GF300HD-BHD	GF300R	GF150BE	GF300BE
PUMPS	GM0MRA	GM2MRA01	GM2MRA01	GM2MRA03	GM2MRA01		GM0MRA	GM0MRA	GM2MRA01	GM2MRA01	GM2MRA01	GM2MRA03
N° OF PISTONS	7	7	7	7	7		7	7	7	7	7	7
TURNS OF WHEEL	3,9	3,3	4,3	6,3	3,3	4,5	5,2	5,2	4,8	4,8	3,1	4,5
CAPACITY CM <sup>3</sup>	16	27	27	32	27		16	16	27	27	27	32
MAX PRESSURE BARS	60	60	60	60	60		60	60	60	60	60	60
CYLINDERS	CE30	CE50	CE75	CE1000	MC150	MC150E	MC150R	MC150BR	MC300HD-BHD	MC300R	MC150BE	MC300BE
BORE Ø [mm]	28	32	32	40	28		28	28	34	34	28	34
VOLUME CM <sup>3</sup>	62	90	118	202	88	123	83	83	130	130	83	146
STROKE [mm]	150	150	215	215	200		200	200	200	200	200	200

## MAVIMARE & MANCINI S.r.l.

Mavimare sales office  
Via Manzoni, 26  
20089 Rozzano (MI) - Italy  
Tel. +39.02.8259190  
Fax +39.02.8241633

---

E.mail: [info@mavimare.com](mailto:info@mavimare.com)  
Web: [www.mavimare.com](http://www.mavimare.com)

**MAVI**  
  
**MARE**